

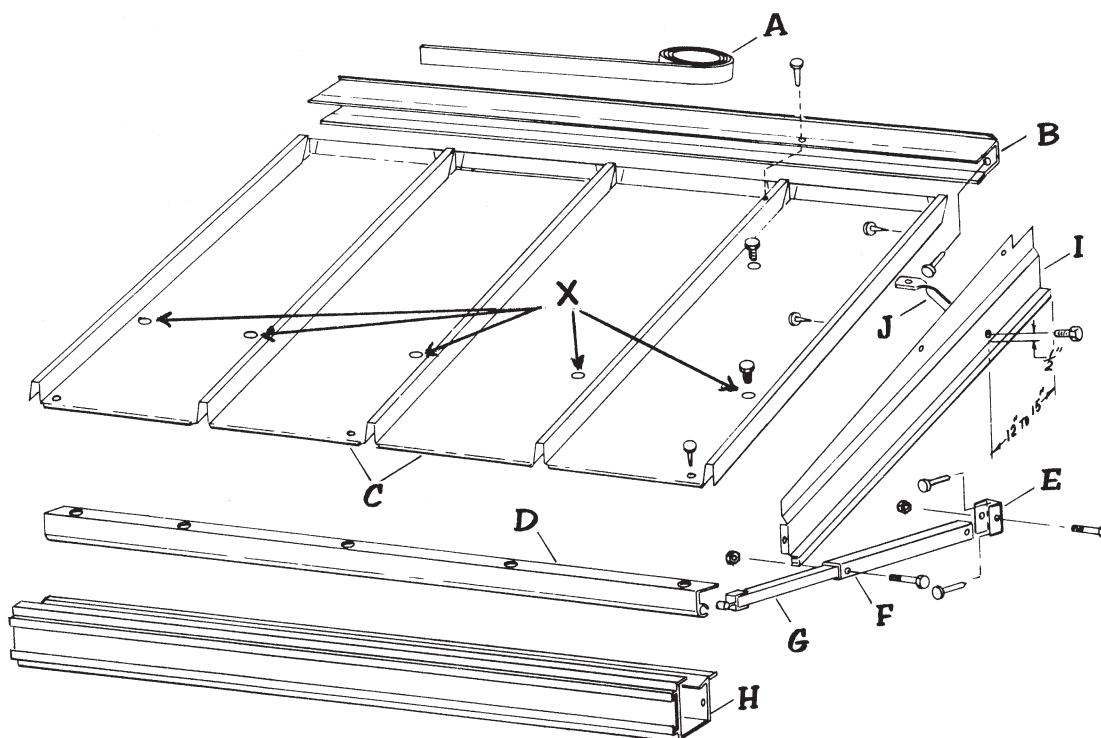

# Window and Door Awnings Assembly and Installation Instructions



1. Place Weather Strip "A" on back of Mounting Rail "B" if not already installed. Remove protective paper.
2. Locate and install Mounting Rail over door or window with #12 x 1-1/2" screws in all pre-punched holes in Mounting Rail. Make sure to locate all Framing Members or Studs and install screws at those locations.
3. On ground or other suitable level area, assemble Awning Panels "C" bottom side up. Locate Front Support Rail "D" six inches from front edge of Awning Panels. Using holes in Front Support Rail as a template, drill 1/8" holes in Awning Panels.
4. Turn Awning Panels right side up and align Front Support Rail holes under holes in Awning Panels. Install a #12 x 1" Self-Drilling Screw with Neoprene Washer through each hole in the Awning Panels and into Front Support Rail. See "X" on drawing above.
5. Place assembled Awning Panels into Mounting Rail and center Awning Panels in Mounting Rail.
6. Establish desired pitch in Awning (approximately 10 degrees is recommended) and support front edge of Awning while installing #8 x 1/2" Self-Drilling screws through top lip of Mounting Rail and into each rib of Awning Panels.

Continued on other side.

---

Check the material received.  
Match your shipment with the Bill of Materials.  
If there is a shortage or wrong material,  
call Dealer Service immediately.

Safety is important!  
Wear Safety Glasses and Work Gloves.  
Follow all safety practices while assembling  
and installing this product.

---

7. Install Foam Weather Seals as each panel is fastened in place.

8. Attach lower Support Arm Brackets “E” to lower Support Arms “F” with 1/4”-20 x 1-1/2” bolt and 1/4”-20 nut.

9. Slide upper Support Arms “G” into lower Support Arms and Front Support Rail.

10. Locate lower Support Arm Bracket slightly below the front edge of the Awning and attach Brackets at edge of door or window casing with two #12 x 1-1/2” screws.

11. Drill 1/4” holes through top of lower Support Arm and bottom of Upper Support Arm. Install 1/4”-20 x 1-1/2” bolt and 1/4”-20 nut.

12. Repeat steps 9 and 10 for opposite Support Arm.

13. Center and attach Gutter “H” to Awning Panels by slipping flange of Gutter into formed lip of Awning Panels. Fasten together at every second Awning Panel with #8 x 1/2” Self-Drilling Screws. End Caps are manufactured and supplied so one (1) or both can be raised to allow water to run out of gutter.

14. Fit Side Trim “I” to Awning Panel by placing tab at front of Side Trim against back side of gutter.

15. Mark and cut back end of Side Trim to fit around Mounting Rail and to be parallel to approximately 1/4” away from home.

16. Place top edge of Side Trim up into Awning Panel rib with tab at front end of Side Trim against back side of Gutter. Attach tab on front end of Side Trim to Gutter with one #8 x 1/2 Self-Drilling Screw and attach top edge of Side Trim to inside of Awning Panel into Side Trim to inside of Awning Panel rib with #8 x 1/2” Self-Drilling Screws (approximately one every foot).

17. Drill 15/64” hole 1/2” above lower flange of Side Trim for lower end of Side Trim Brace “J”. Attach lower end of Side Trim Brace to Side Trim with 1/4”-20 x 1/2” self tapping, wax tipped screw.

18. Mark hole location on Awning Panel through hole in top end of Side Trim Brace. Drill 15/64” hole in Awning Panel and install a 1/4”-20 x 1/2” self tapping, wax tipped screw down through the Awning Panel and into the Side Trim Brace.

**Note:** To prevent Support Arms from sliding out of position, compress the inside circular portion of Front Support Rail “D” on each side of upper Support Arms “G”.

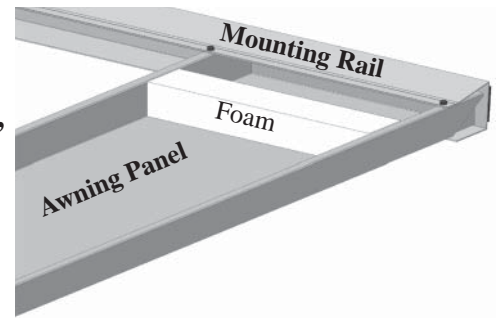

---

Dura-Bilt Products, Inc. P.O. Box 188 Wellsburg, N.Y. 14894

Dealer Service 1-570-596-2000 E-Mail [info@durabilt.com](mailto:info@durabilt.com)

DURA-BILT RESERVES THE RIGHT TO CHANGE DESIGN AND/OR SPECIFICATIONS WITHOUT NOTICE.