



Assembly and Installation Instructions

Standard 3-Season Sunroom Enclosure Deluxe Screen Room Full Screen Room Under Dura-Lock Dura-Therm Aluminum Awning Galvalume Patio Cover

Read the instructions before starting the job. They explain the steps required to produce a finished product that will meet factory specifications.
All references to “Left” and “Right” are while facing the home.









Check the material received.
Match your shipment with the Bill of Materials.
If there is a shortage or wrong material,
call Dealer Service immediately.

Safety is important!
Wear Safety Glasses and Work Gloves.
Follow all safety practices while assembling
and installing this product.

Dura-Bilt Products, Inc. P.O. Box 188 Wellsburg, N.Y. 14894

Dealer Service 570-596-2000 E-Mail info@durabilt.com

DURA-BILT RESERVES THE RIGHT TO CHANGE DESIGN AND/OR SPECIFICATIONS WITHOUT NOTICE.

Fasteners	
Fastener	Description
	1/4" - 20 X 1-1/2" Bolt & Locking Nut
	#12 X 2" Slotted Hex Head Screw
	#10 X 1" Hex Head Screw Magni 599 Coated
	#12 X 1-1/4" Self Drilling Screw
	#12 X 3/4" Self Drilling Screw
	#8 X 1/2" Self Drilling Screw
	Plastic Lag Shield
	#10 X 1-1/2" Flat Head Phillips Screw (They come with the threshold)

Tools Required

Cordless Drill Tape Measure Metal Saw Level Chalk Line Clamp Hammer
 Utility Knife Caulk Gun Silicone Lubricant Spray

Nut Driver Bits with Magnetic Head: 1/4" - 5/16" - 7/16" Drill Bits: 13/64" - 1/4" Masonry

Component Descriptions

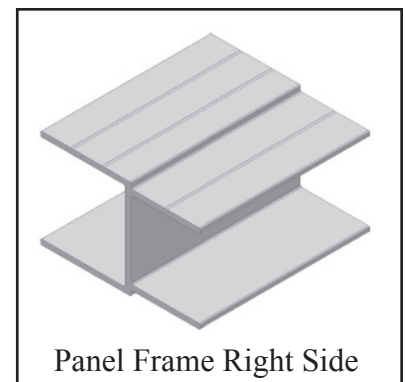
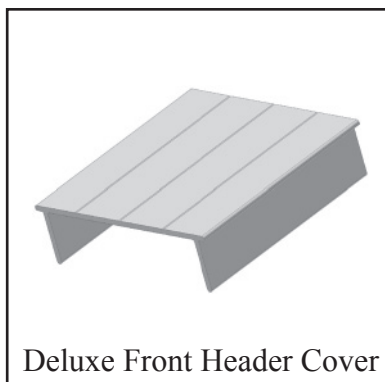
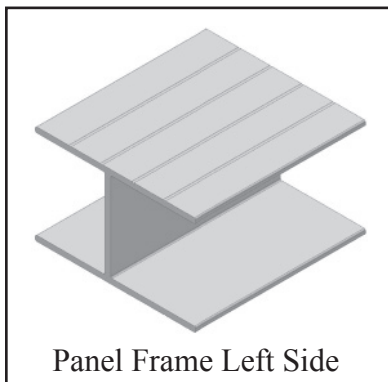

Component Descriptions

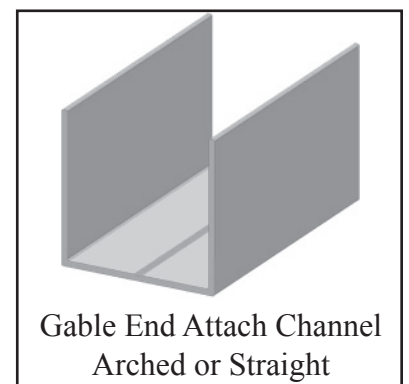
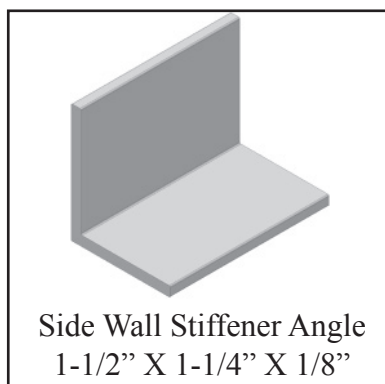
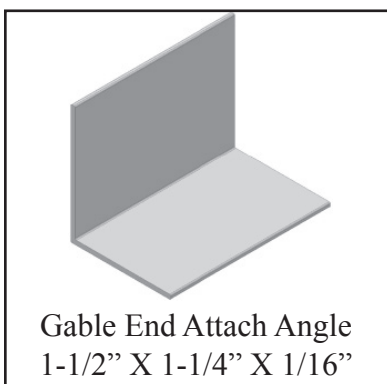
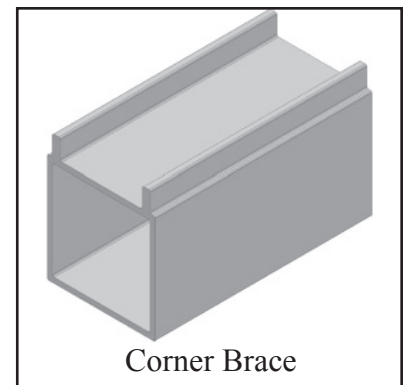
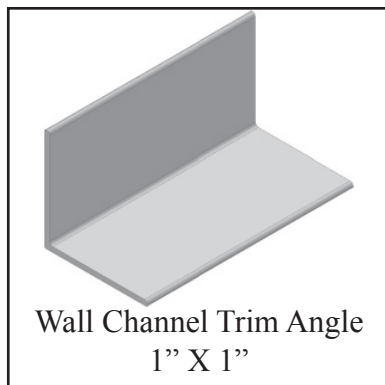
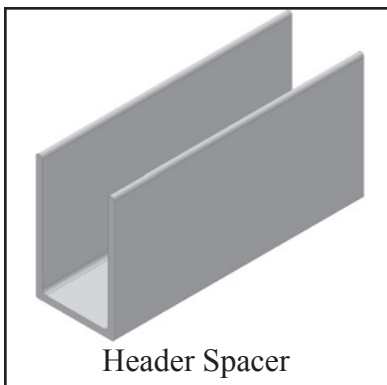
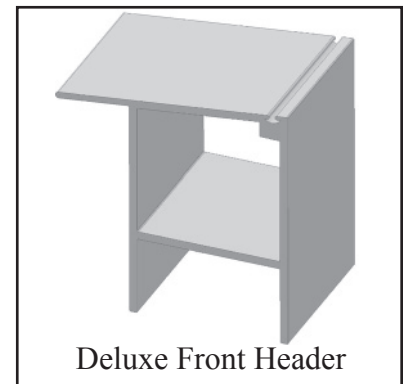
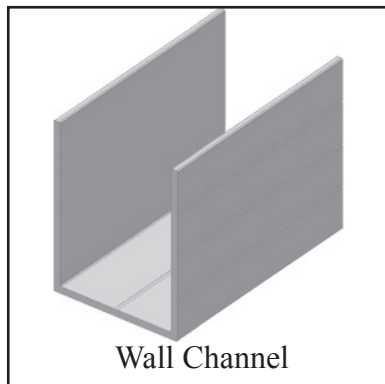
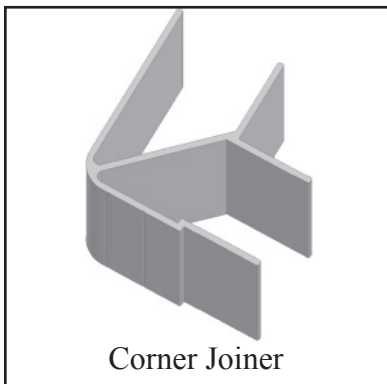
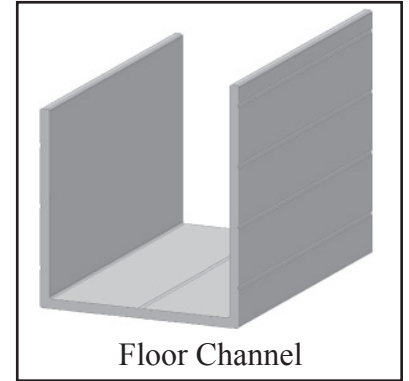
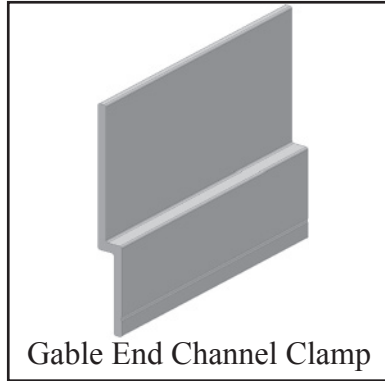
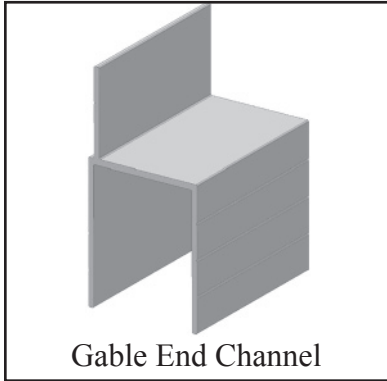

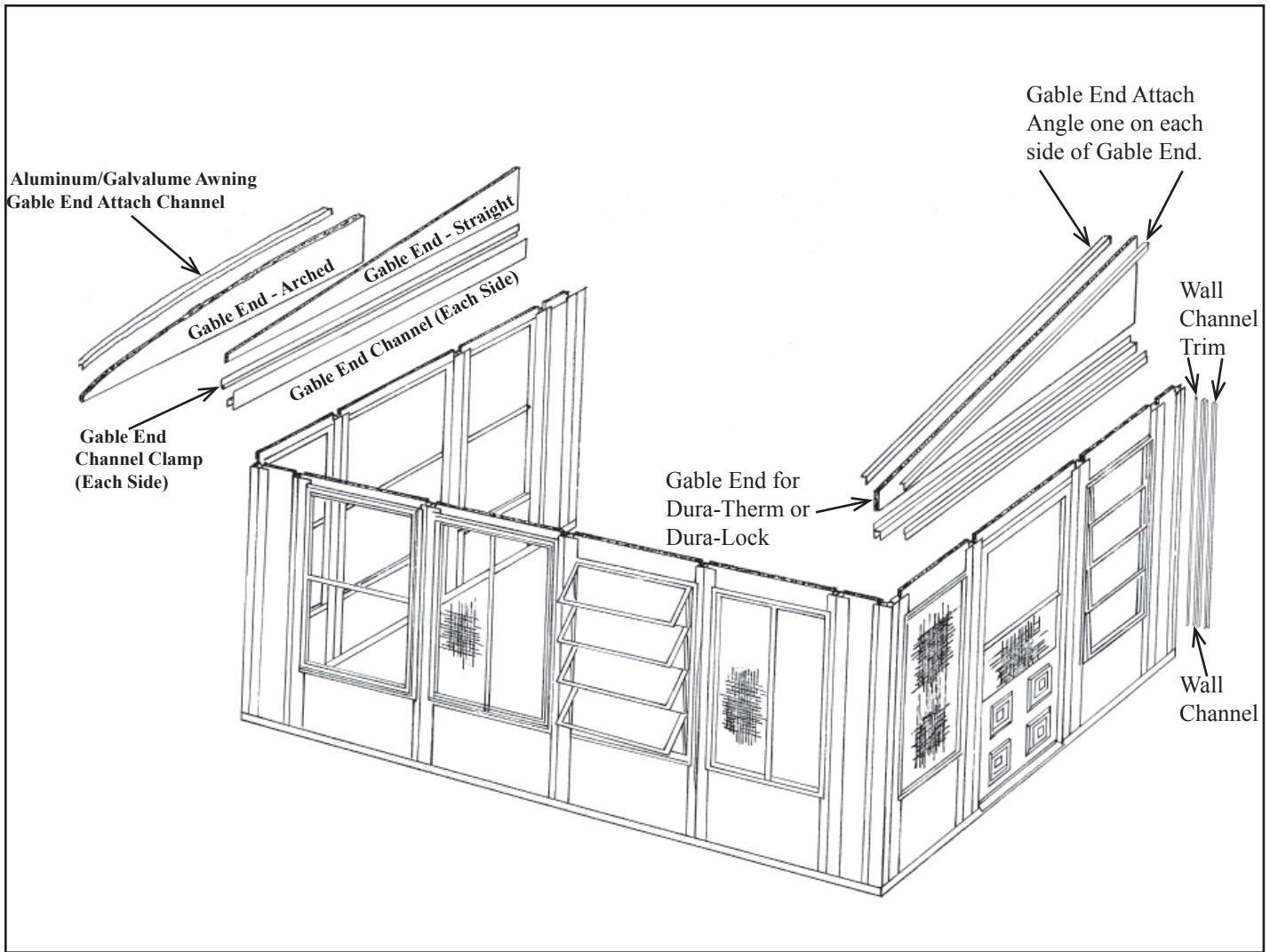

1. If you are installing a Dura-Bilt Roof and Enclosure at the same time, the Mounting Rail is installed first. Read the appropriate installation instructions (Aluminum Awning, Dura-Therm or Dura-Lock) for the proper procedure.

2. If the roof is already installed, it is necessary to raise the front of the roof several inches above the proposed Enclosure wall height and brace it in position. Remove any Roof Post Assemblies not needed.

3. Length of Enclosure is distance between outer legs of end wall Floor Channels. (As shown on the Wall Layout Diagram.)

4. Width of End Wall is measured from back of Wall Channel to front side of Floor Channel.

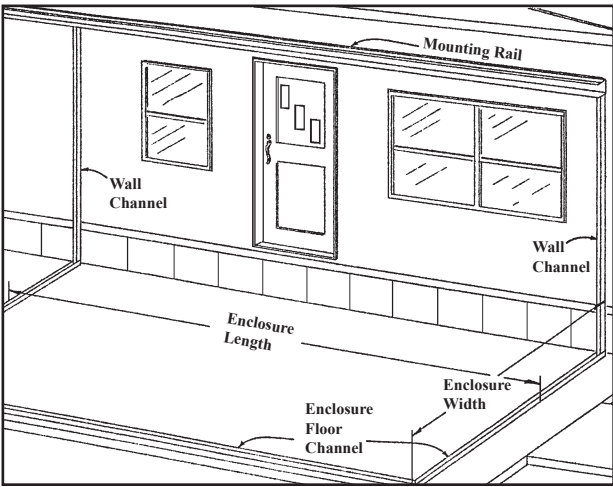

5. Enclosure End Walls must **not** be located directly under Aluminum Awning Rib or Dura-Therm Girder due to method of attaching Gable End to Roof Panel.

6. If roof is already installed, the front Floor Channel is located by dropping a plumb line from the **inside** Leg of the Front Header to the Patio. This will mark the inside position of the Floor Channel.

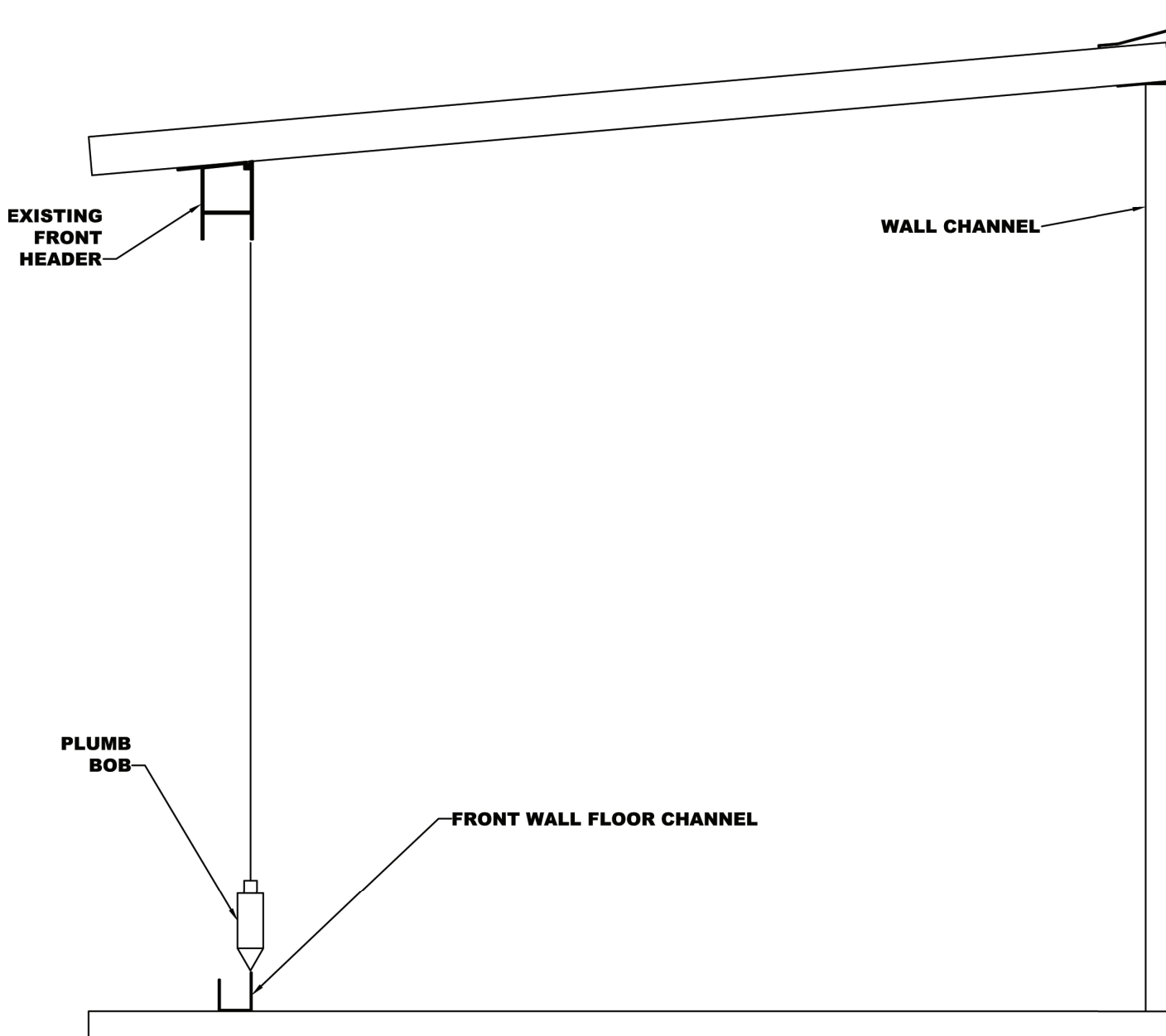

The following is for an Aluminum, Galvalume or Dura-Lock Awning.

7. If a new Front Header is required, it is located to the selected end wall width and attached with #12 x 3/4" screws with washer in the same manner as the original Front Header. Floor Channel is then located as described above.

8. Cut enclosure Floor Channel as shown and install.

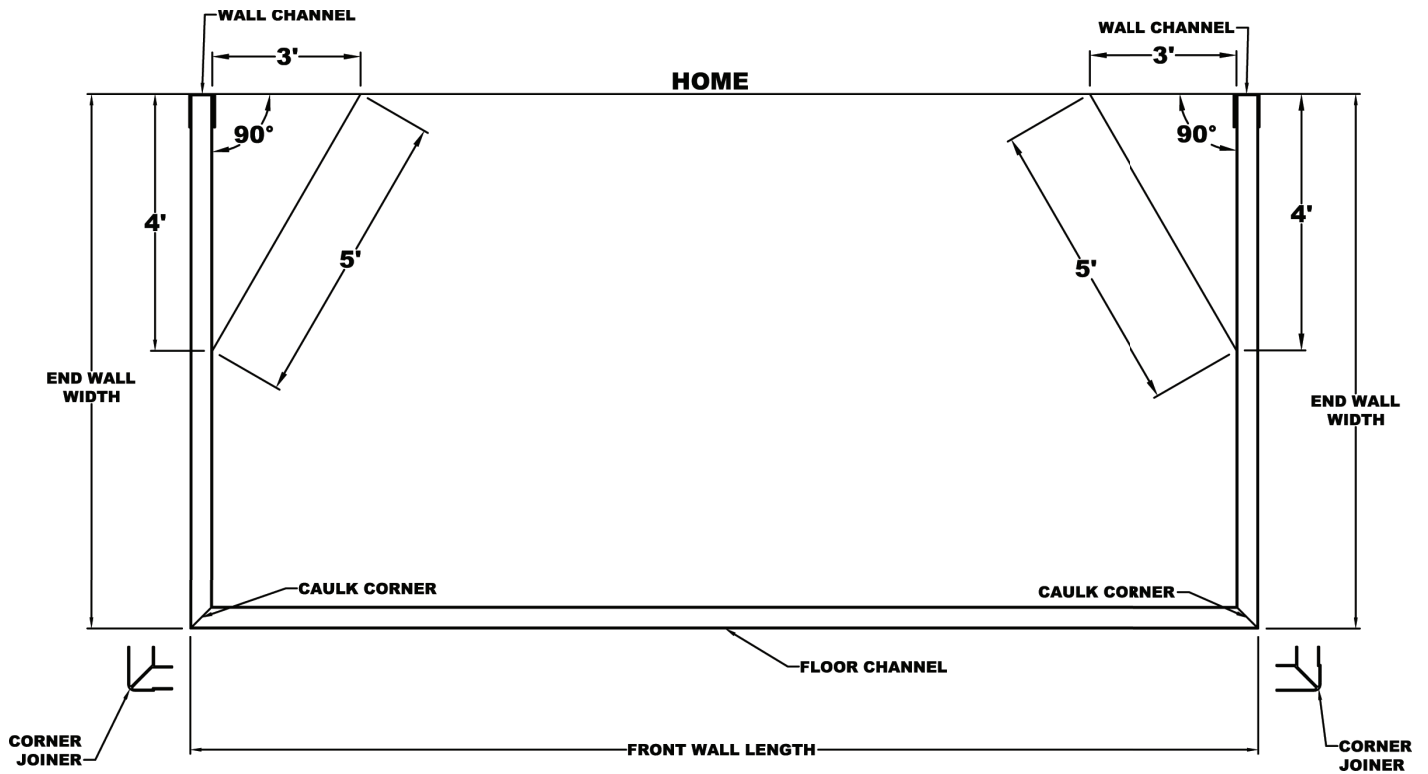
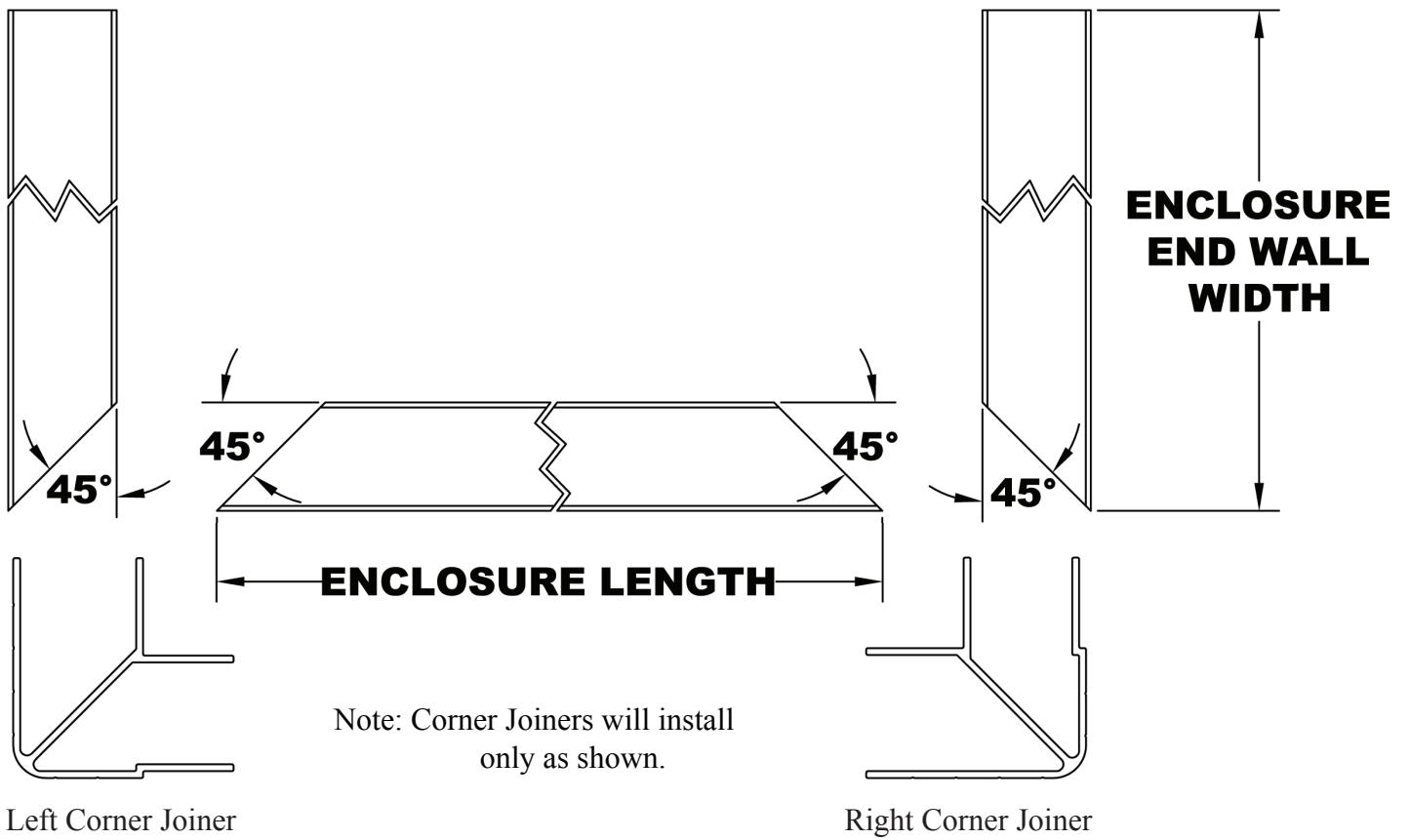

9. Lay out enclosure dimensions with chalk line. Use 3, 4, 5 or similar method to establish 90 degree corners.

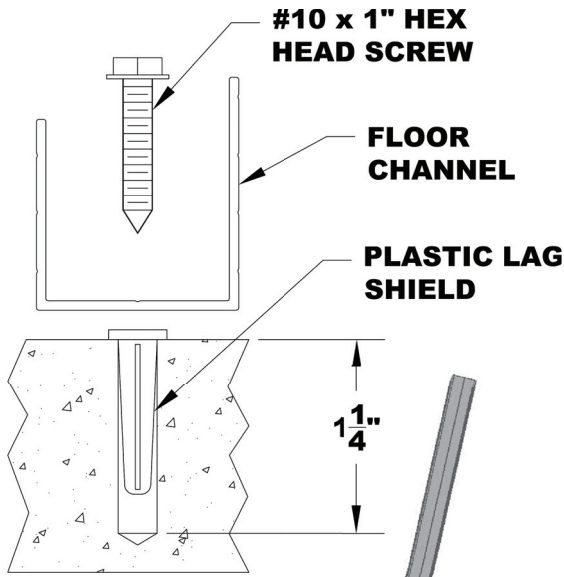

10. Drill 13/64" holes in Floor Channel every 12 inches. Place Floor Channel in position and mark location for 1/4" plastic shields.

11. Drill holes for plastic lag shields with 1/4" masonry drill bit.

12. Install 1/4" plastic lag shields in holes. Run a bead of caulk under Floor Channel, covering the holes. Then position Floor Channel and install #10 X 1" screws through Floor Channel and into plastic lag shields.

Wood Deck: Caulk the bottom of the Floor Channel covering all of the drilled holes and mitered corners. You must use the #10 x 1" hex head screws with the Magni 599 coating supplied by Dura-Bilt every 12 inches.

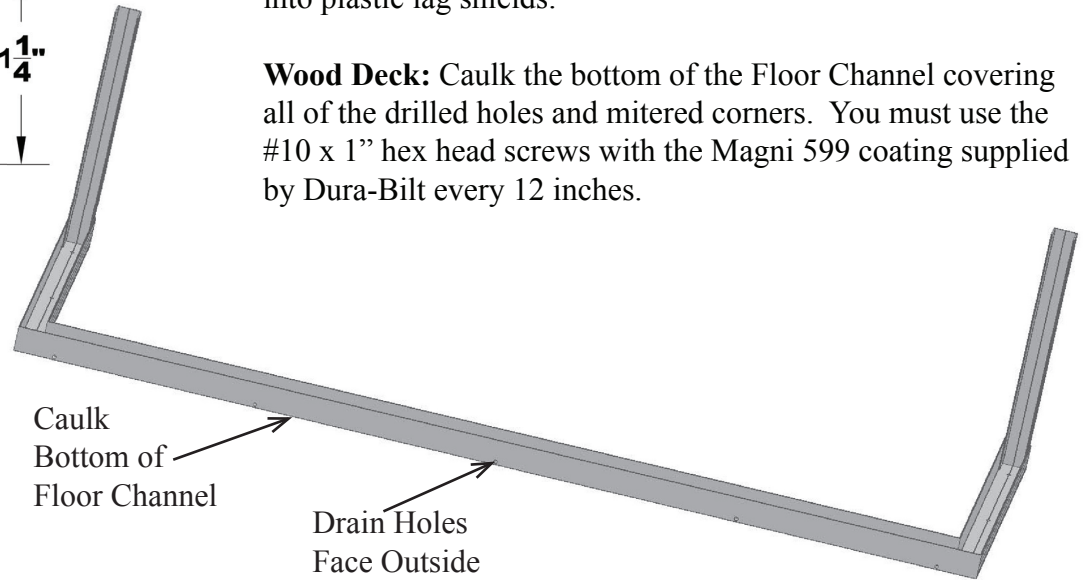

13. Cut top of the Wall Channel to fit under Mounting Rail, with the bottom of the Wall Channel within 1/8" of the patio or deck. Apply Weather Seal to back of Wall Channel and locate vertically on the home, spaced for the length of the Enclosure selected. Attach Wall Channels to the home with (5) #12 X 2" hex screws.

#12 X 2" Hex Screw (5 Places).
Use 11/64" Drill Bit in Home.
Use 7/32" Drill Bit in Channel.

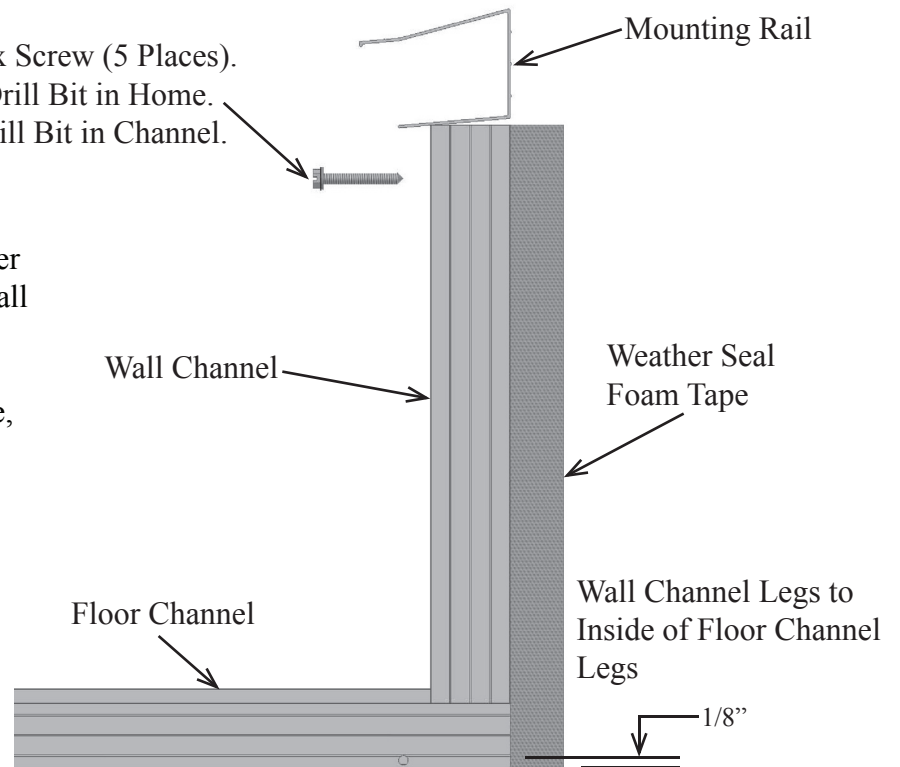

14. Assemble the Front Header per Roof Instructions.

IMPORTANT!
READ INSTRUCTIONS #16-#19 BEFORE CONTINUING INSTALLATION.

15. You are now ready to install the Enclosure Panels. First locate the two panels with notches cut into the Panel Frames. These are marked for Right and Left Corners. Then locate Corner Joiners in the Hardware Kit. These are also marked for Right and Left. Set the Panels and Corner Joiners aside. The first panel to be installed is in the Left Wall Channel. Refer to your Wall Layout for Wall Panel positions.

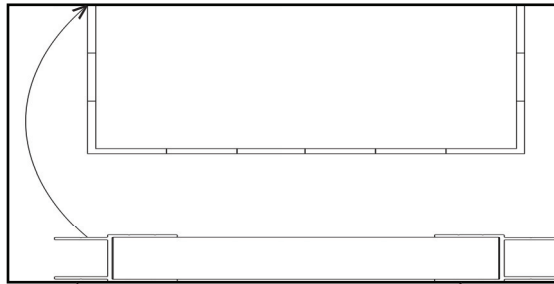

Panel with narrow extrusions on both sides installs in Left wall channel only!

A label (shown at left) is attached to the Left Wall Solid Panel. It is the first panel to be installed.

Note: Screen Room Wall Panels are to be installed with the screen splines on the **outside** of the room.

As you install the Panels into the Wall Channel, plumb each panel and install #8 X 1/2" self drilling screws through Floor Channel and into Panel Frame as shown in Figure below.

In many cases, the wall of the home is not plumb and can make it difficult to fit panels into the Wall Channel. With the Solid Panel at the home, you can correct this condition.

Example: If the home is tilted back. Remove Panel Frame Extrusion, determine and mark the amount to be removed from the Panel so that opposite side of Panel will be plumb.

Cut Panel and reinstall the Panel Frame Extrusion.

Remove Panel Frame Extrusion.
Mark and cut Panel as required.
Install Panel Frame Extrusion.

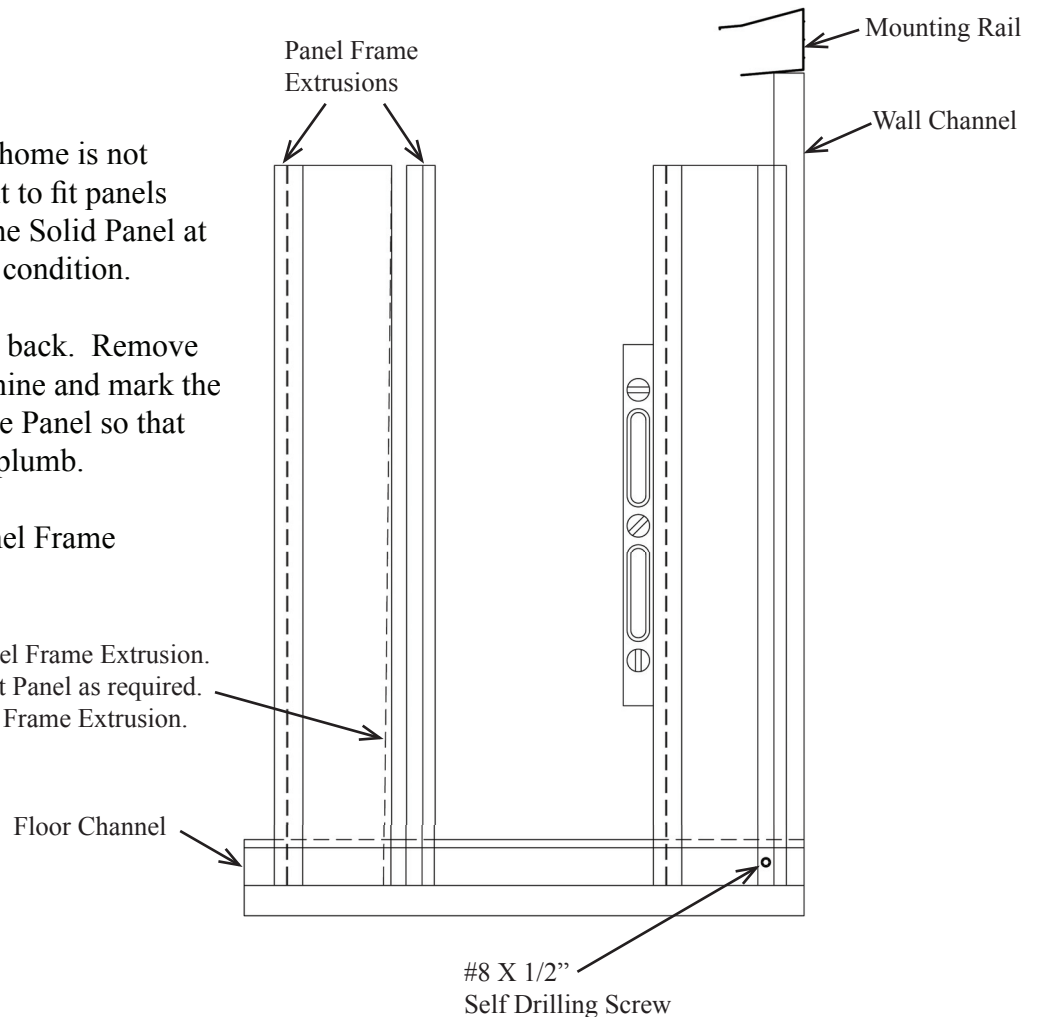

Continue installing Panels by positioning each Panel, or Corner Joiner, so its legs will slide over legs of Panel already in place.

Illustration shows Enclosure Side Wall installed. View from top shows Frame overlap. Door Panel(s) will install in the same way shown for Window Panels.

All fasteners are #8 X 1/2" self-drilling screws installed inside or outside where legs on Panel Frames overlap.

Important: NOT installing screws through Wall Channel into Wall Panel helps prevent damage to home and enclosure due to frost heave.

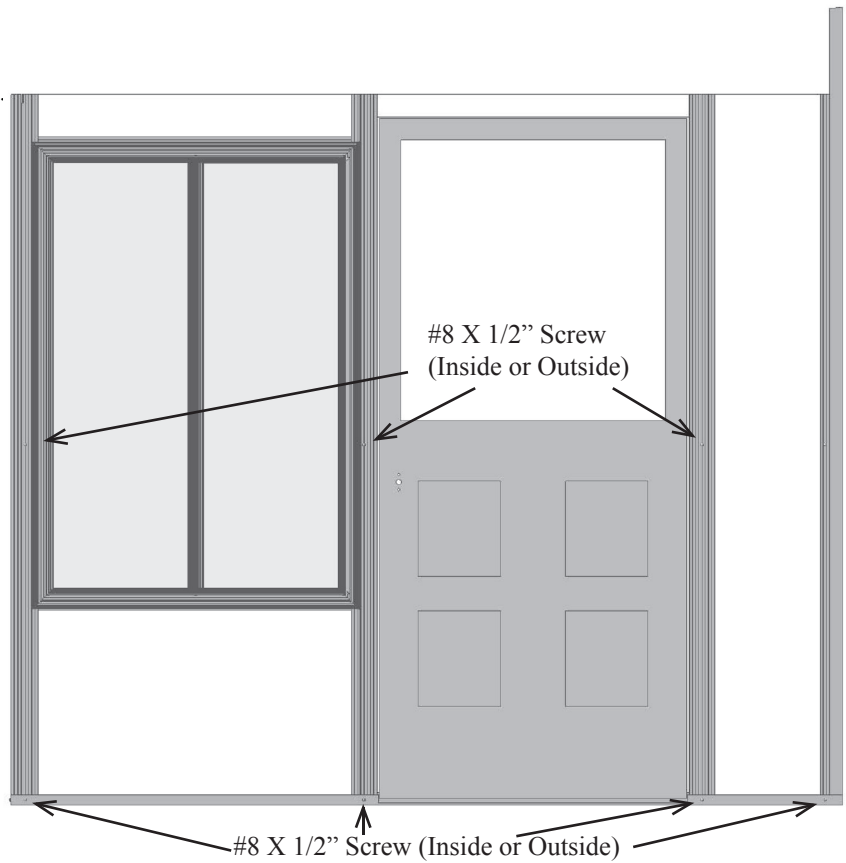

16. Before installation of the Door Panel, the Floor Channel Side Walls must be cut for the Door opening. As indicated below, the door hinge side of the Floor Channel is cut slightly larger to accommodate the door swing. Locate Door Panel and mark sides of Floor Channel accordingly. Remove Door Panel and cut side walls of Floor Channel as marked.

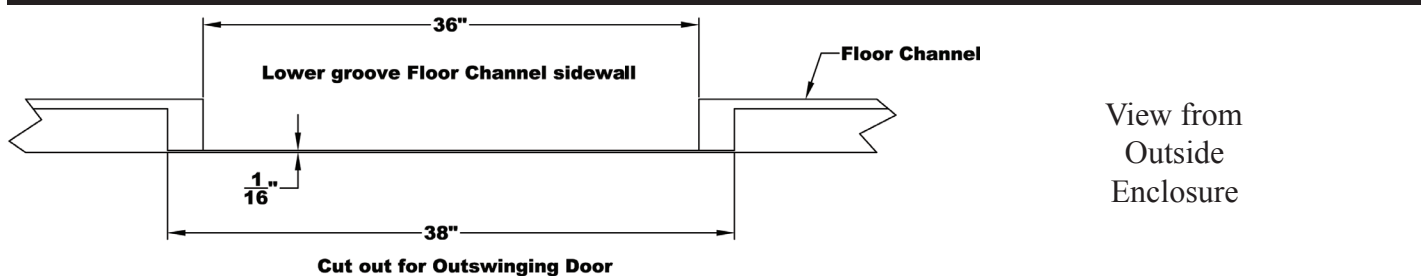
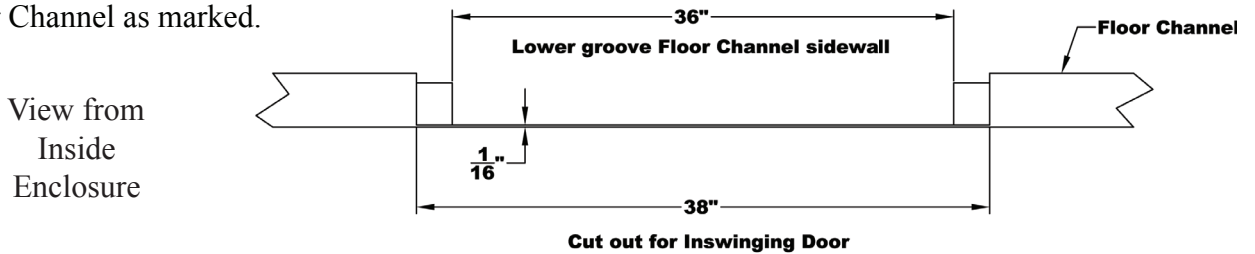

Note: The Door Panel is 3/16" narrower than the equivalent Window Panel. Allow 3/32" spacing on each side when installing Door Panel. See Figure below.

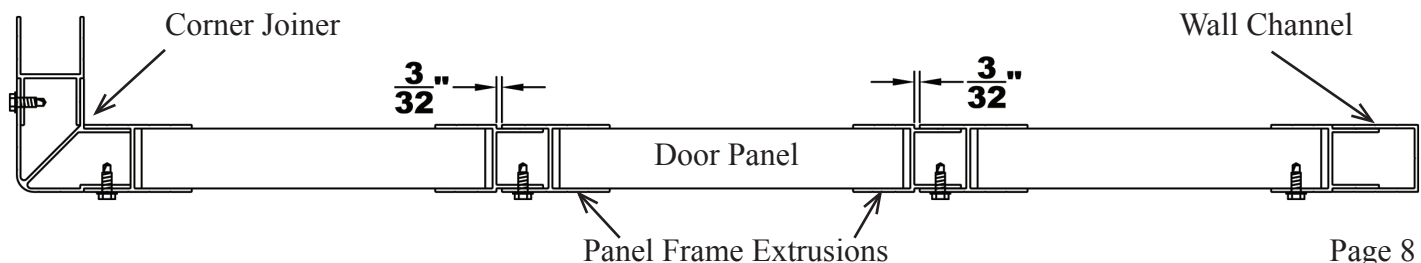

When possible, it is best to work in both directions toward the Door location and install the door last.

17. Start at Left Wall Channel and install Panel identified for left Wall Channel only and work toward Door location. Then go to Right Wall Channel and install Wall Panels, working your way back around to the Door location.

18. If you are installing a second door, install that door using the same procedure as you would with a Wall Panel.

Deluxe Front Header Cover is supplied to cover the overhang of Deluxe Front Header. Attach with #8 x 1/2" Screws.

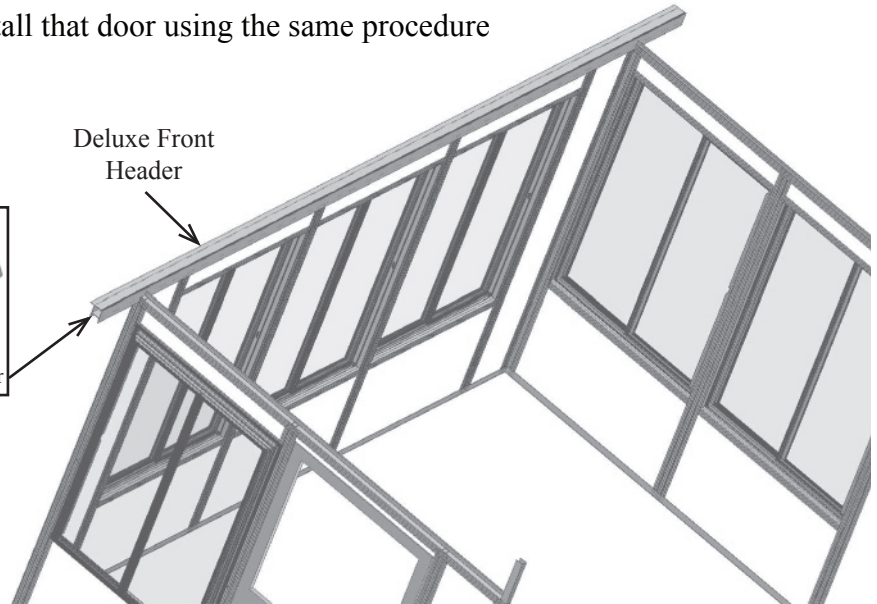
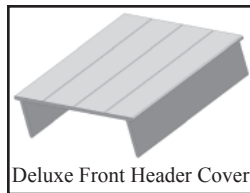

19. After all Enclosure Panels have been installed, place Front Header that you assembled in Step 15 over the Front Enclosure Wall. **Note that Corners and adjacent panels have been notched at top to accommodate Front Header.**

20. Level Front Header on the Front Enclosure Wall. Then raise center of Header slightly so that water will flow to downspouts.

21. Position Spacer between Wall Panel and Front Leg of Header and fasten with #12 x 1-1/4" self-drilling screws, through front leg of header, continuing through spacer, then into corners and panel frame. See drawing below.

22. Attach the Inside Leg of the Front Header to the Panel Frames with #12 x 3/4" self-drilling screws where Panel Frame Extrusions overlap. See drawing below.

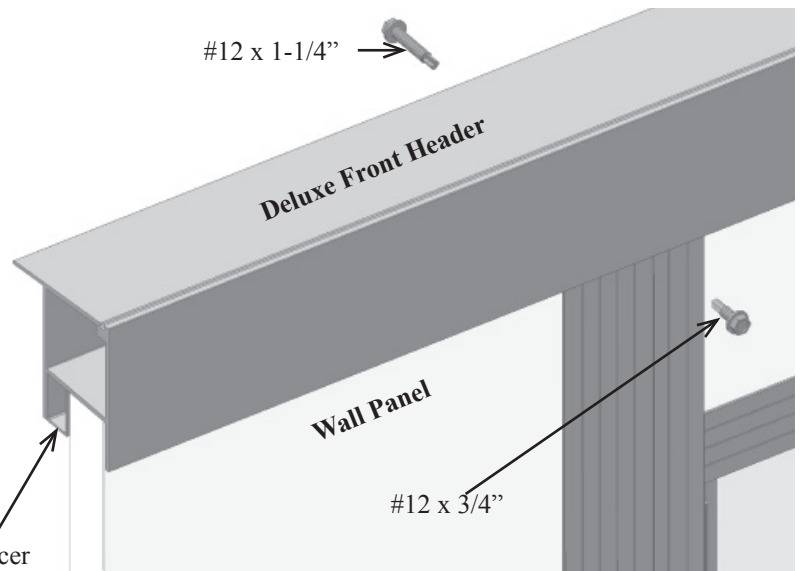
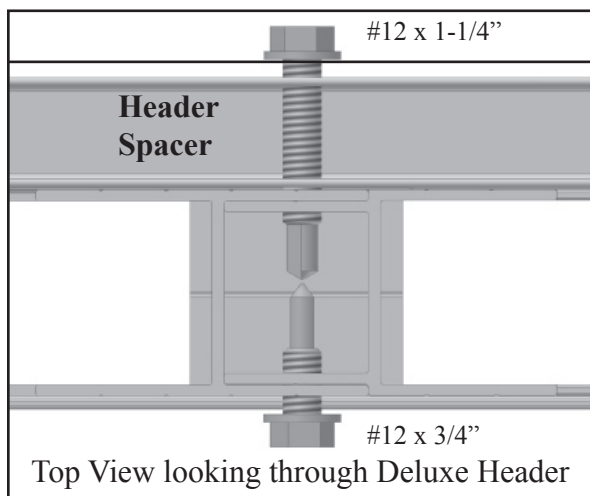

Note: If you have an existing roof you can lower it and secure it at this time. If you have a new roof install the roof panels now according to instructions provided.

Gable Ends

The Gable End Channel is provided in two parts to allow for easier installation of the Gable End when the Awning/Roof Panels have been previously installed.

1. Cut the Gable End Channel to fit from the back of the Deluxe Front Header to the back of the Wall Channel.
2. Cut two (2) slots $1/8''$ wide x $1-1/2''$ deep into the top surface of the Gable End Attach Channel. This is done so the Gable End Attach Channel fits around the Wall Channel. **See drawings below.**

Note: The end of the Gable End Channel with the $1/8''$ slots is inserted around the Wall Channel above the Enclosure Side Wall Panels and then pushed down over Panel Frames until it rests on Panel Frames. **With $76-1/2''$ and $82''$ wall height, Gable End Channel will not seat fully on Panel Frames at the door. This may cause a high spot in the Gable End Channel. It can be leveled by raising the ends of the Gable End Channel. However, as you install $\#8 \times 1/2''$ self drilling screws where two Panel Frames overlap and intersect Gable End Channel, be sure to hit the Panel Frames with screws.**

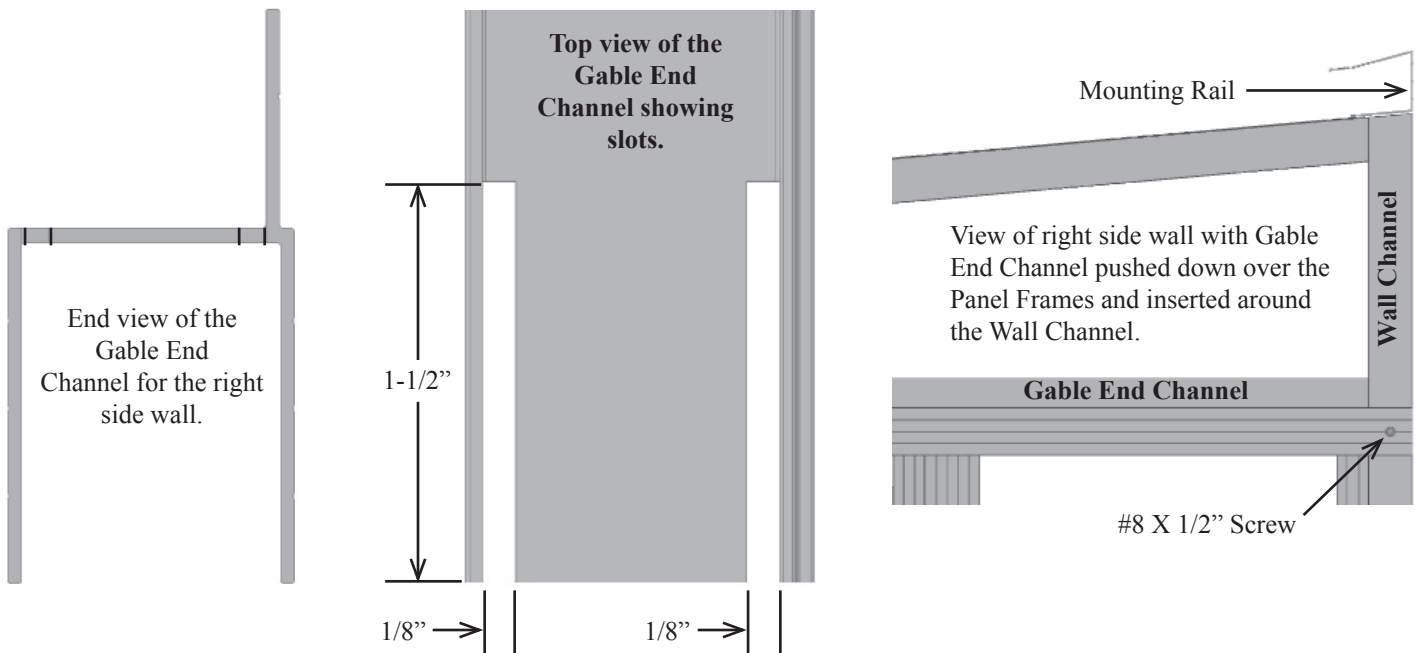

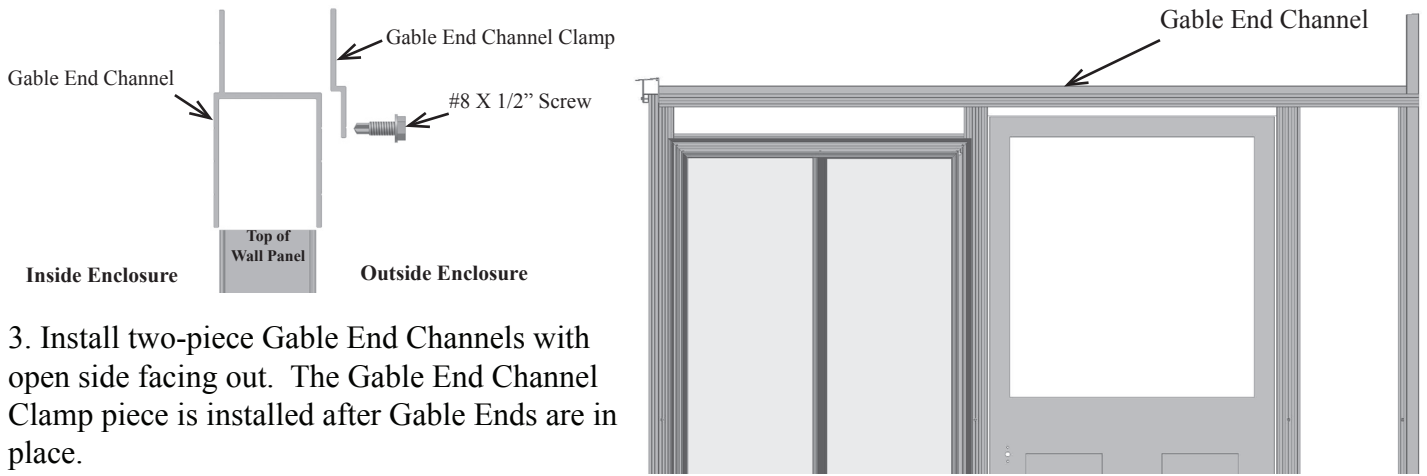

3. Install two-piece Gable End Channels with open side facing out. The Gable End Channel Clamp piece is installed after Gable Ends are in place.

4. Gable End Material for Arched Roof is supplied with arch pre-cut. Material for Straight Roof is one piece and must be cut in half diagonally corner to corner. Gable Ends must now be cut to fit, see Step 5 on Page 12.

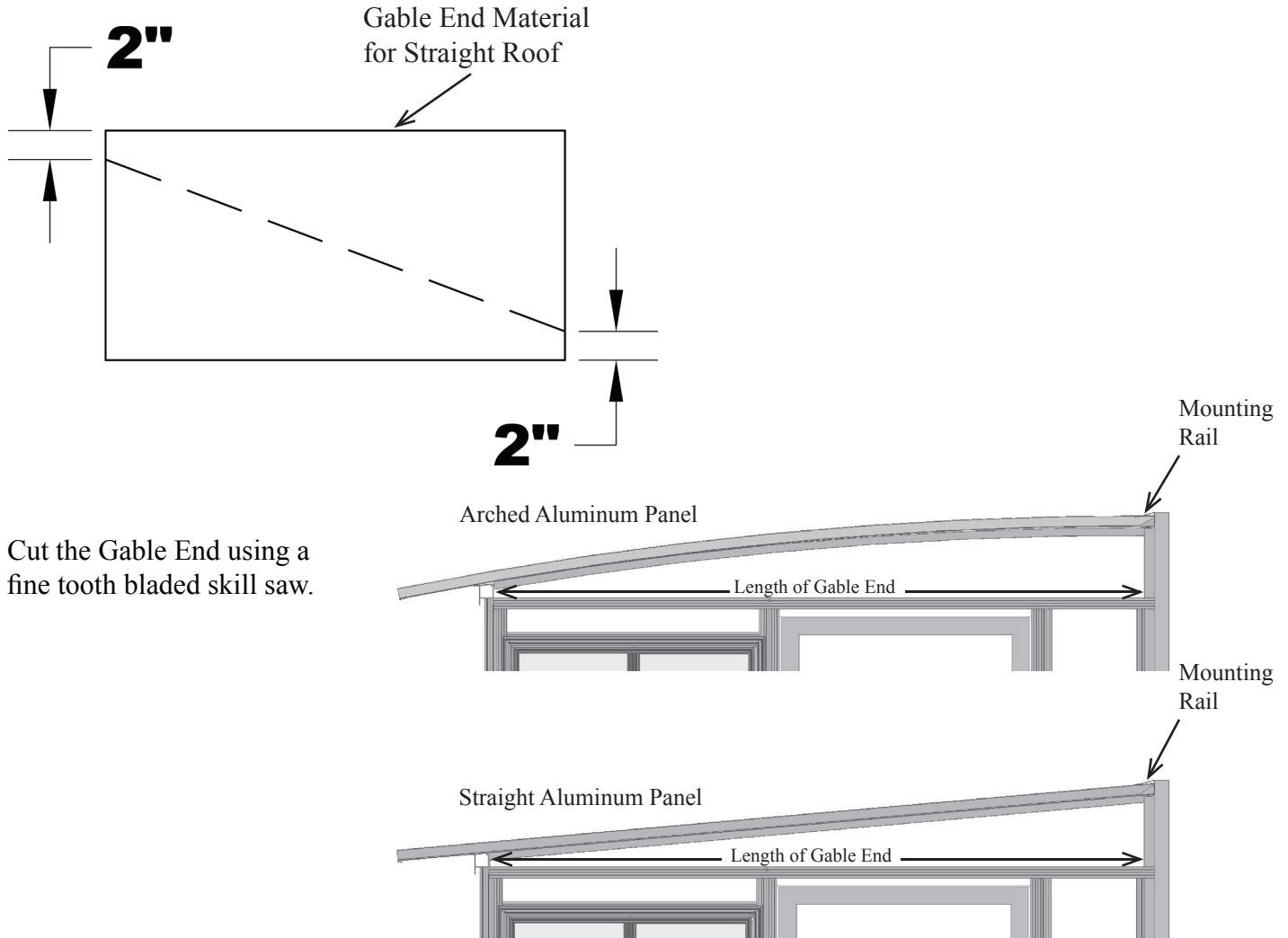

Cut the Gable End using a fine tooth bladed skill saw.

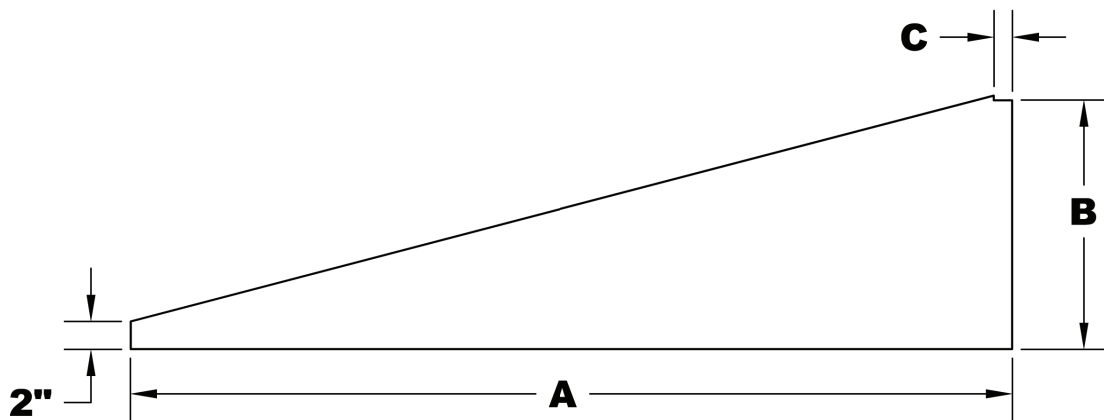

5. Make the following measurements and mark them on the Gable End. Follow this procedure **for each** End. Measure distance (A) from inside of Enclosure Wall Channel to back of Front Header. Measure distance (B) from bottom of Gable End Channel to under side of Roof Panel. Mark these measurements on the Gable End as shown in drawing.

Cut Notch (C) as shown to fit around Mounting Rail.

6. Cut the Gable End to your measurements. Check final size, it must fit from the back of the Enclosure Wall Channel to the back side of the Front Header.

7. Follow same measuring procedure for the other Gable End.

For Aluminum or Gavalume Roof :

8. Locate Gable End Attach Channel flush with front end of Gable End and cut 1-1/2" off at back so Gable End will fit into the Wall Channel, then install #8 x 1/2" screws approximately every 18". When installing roof panel use #8 x 1/2" screws through top of Awning Panel into the Attach Channel approximately every 18 inches.

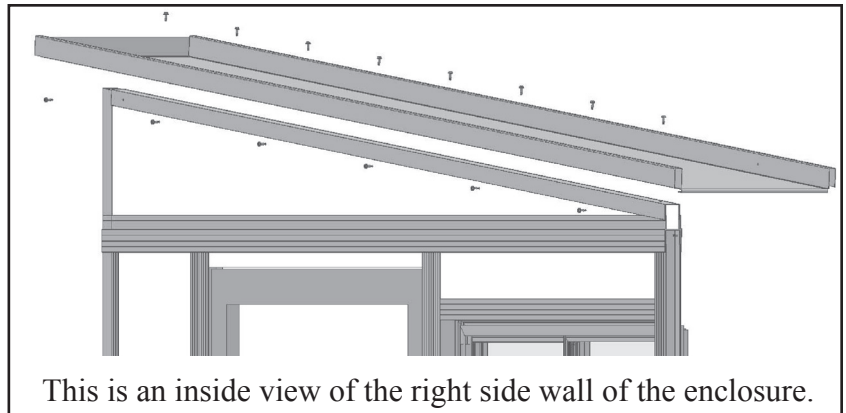

This is an inside view of the right side wall of the enclosure.

Dura-Therm and Dura-Lock Roofs :

Install the Gable End Attach Angles with #8 x 1/2" screws every 12".

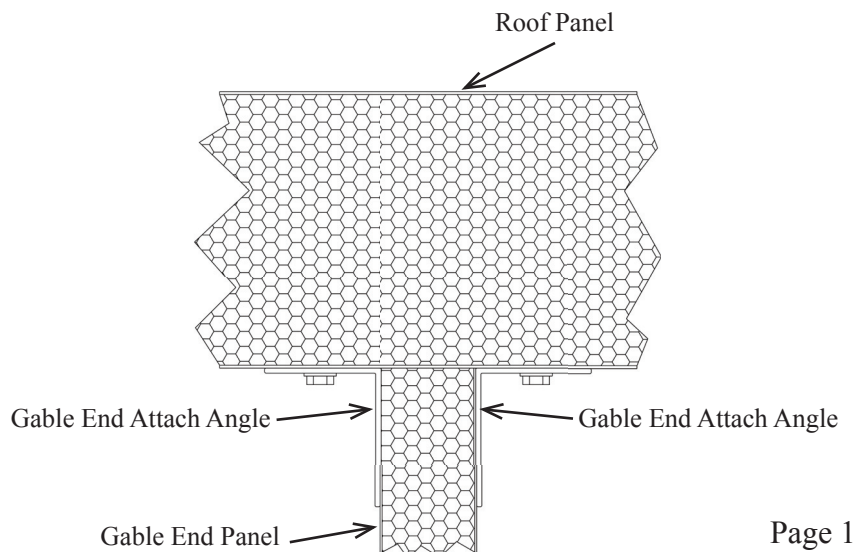

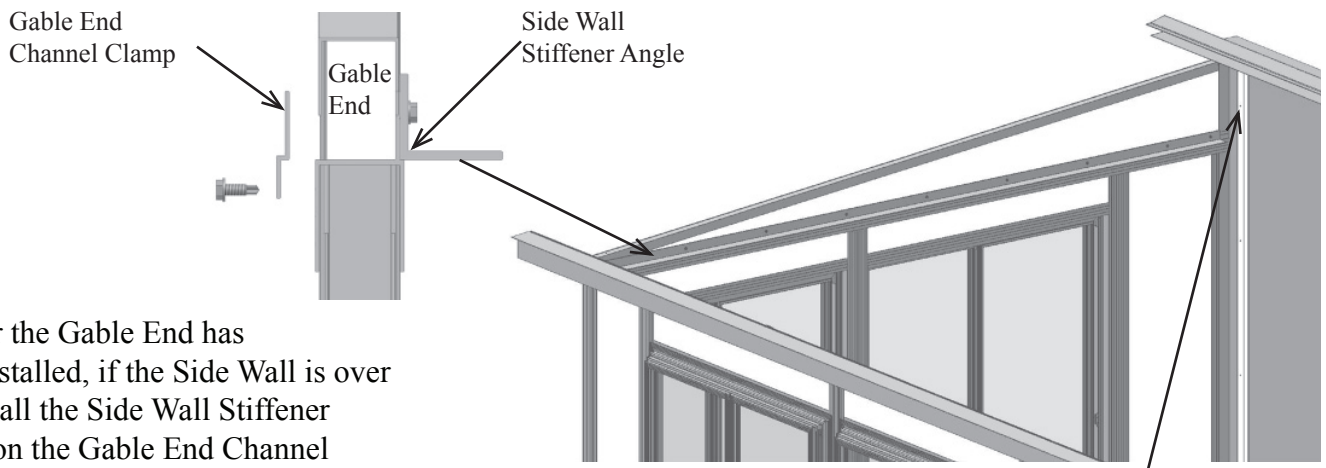

9. After the Gable End has been installed, if the Side Wall is over 10' install the Side Wall Stiffener Angle on the Gable End Channel with #12 x 3/4" self drilling screws in the pre-punched holes.

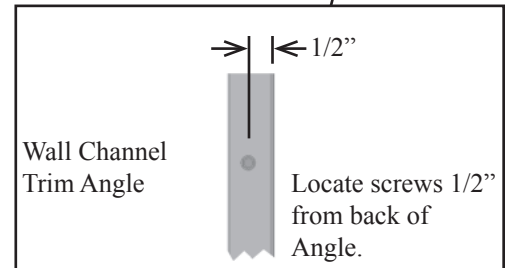

Place Wall Channel Trim against Wall Channel with one leg against home to cover weather stripping and caulking. Caulk between house and Wall Channel before fastening Wall Channel Trim to Wall Channel with five (5) #8 x 1/2" self drilling screws.

Wall Channel Trim is furnished in 120" lengths and must be cut to fit for both inside and outside of Wall Channel.

Use of Corner Braces may be optional.

Consider use of Braces as optional on Side Walls up to 12' in length. Braces are recommended for Side Walls more than 12' in length. Braces also recommended for all walls in "**high wind**" areas.

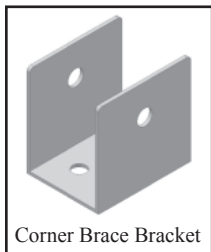

Corner Brace Bracket

Installing Corner Brace on Room with Gable End Channel

1. Install Corner Brace Bracket on back side of Front Header with (2) #12 x 3/4" screws.

2. Attach Corner Brace to Bracket with two (2) 1/4-20 x 1-1/2" bolt with locking nut.

Do not tighten at this time.

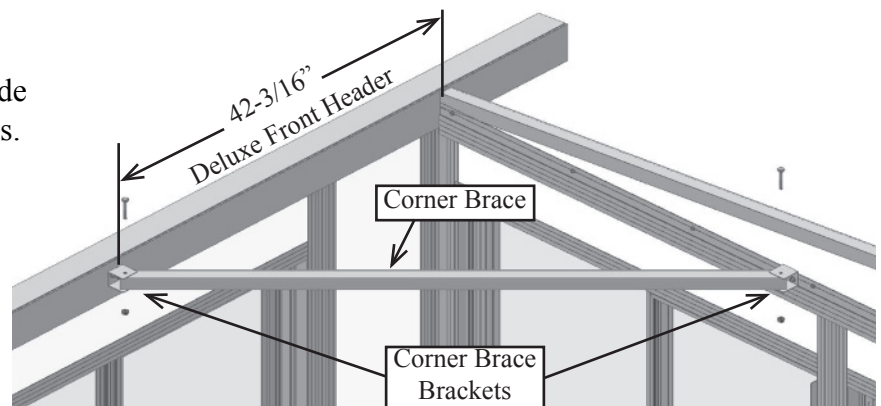

3. Swing the free end of Brace to Enclosure Side Wall and position Bracket on Gable End Channel where holes in Bracket and holes in Brace are aligned.

4. Attach Bracket to Gable End Channel with (2) #12 x 3/4" self drilling screws. Install and tighten all locking nuts on 1/4-20 x 1- 1/2" bolts.

Installing Corner Brace on Room with Side Wall Stiffener Angle

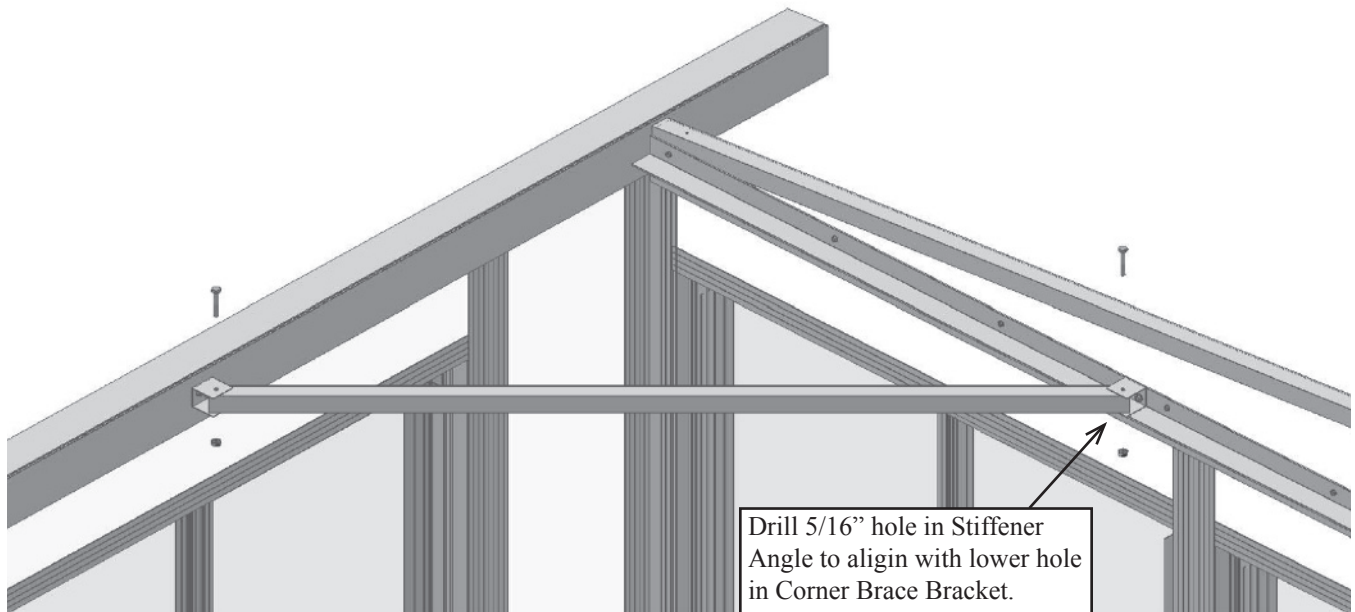

1. Install Corner Brace Bracket on back side of Front Header with (2) #12 x 3/4" self drilling screws as shown above.
2. Attach Corner Brace to Bracket with (2) 1/4-20 x 1- 1/2" bolts with locking nuts. **Do not tighten at this time.**
3. Swing the free end of Brace to Enclosure Side Wall and position Bracket on Side Wall Stiffener Angle where holes in Bracket and holes in Brace are aligned.
4. Attach Corner Brace Bracket to Stiffener Angle as shown. Use (2) #12 x 3/4" self drilling screws. Drill one 5/16" hole inside Wall Stiffener Angle to align with hole in Corner Brace Bracket. Place Corner Brace in position and install and tighten all locking nuts on 1/4-20 x 1-1/2" bolts.

Installing the Threshold

1. Cut Threshold to 35-1/2". Notch for in-swinging or out-swinging Door as shown on next page. Install with 1/4" plastic lag shields and #10 x 1-1/2" screws, unless Threshold is installed on a wood deck, in which case, omit plastic lag shields.

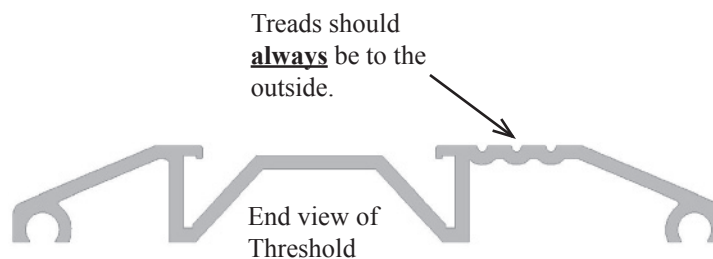

Threshold for Outswinging Door

Both sides of the Threshold are to be notched the same.

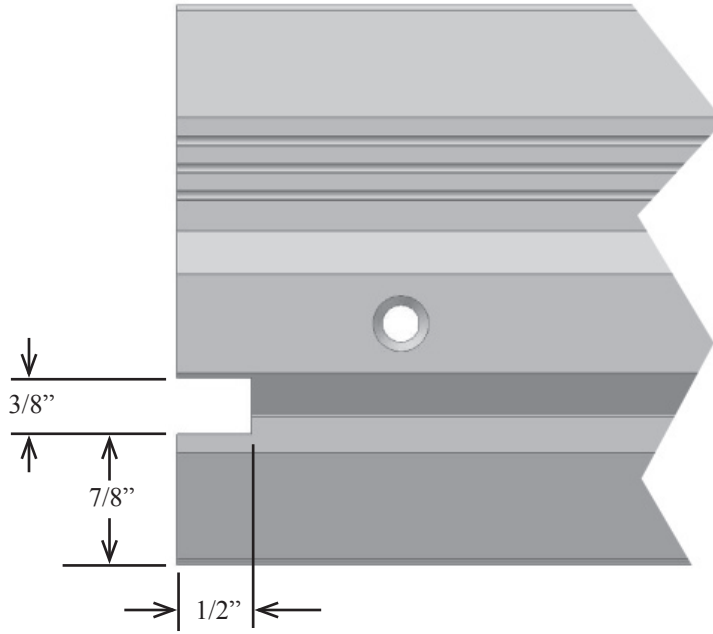

Threshold for Inswinging Door

Both sides of the Threshold are to be notched the same.

