



# Deluxe Dura-Fold Portable RV Awning

## Assembly and Installation

### Instructions



Read the instructions before starting the job. They explain the steps required to produce a finished product that will meet factory specifications.  
All references to “Left” and “Right” are while facing the home.

Check the material received.  
Match your shipment with the Bill of Materials.  
If there is a shortage or wrong material,  
call Dealer Service immediately.

Safety is important!  
Wear Safety Glasses and Work Gloves.  
Follow all safety practices while assembling  
and installing this product.









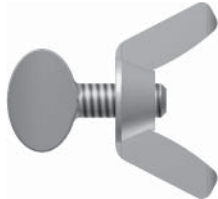

---

Dura-Bilt Products, Inc. P.O. Box 188 Wellsburg, N.Y. 14894

*Dealer Service 570-596-2000 E-Mail [info@durabilt.com](mailto:info@durabilt.com)*

DURA-BILT RESERVES THE RIGHT TO CHANGE DESIGN AND/OR SPECIFICATIONS WITHOUT NOTICE.

## Fasteners

	<p>#14 x 4" Self Drilling Screw with 1-1/2" EPDM Washer</p>
	<p>#14-10 x 2-1/2" Galvanized Hex Washer Head Screw <b>Attaches Anchor Bracket to Wooden Deck.</b></p> <p><b><u>(Full Embedment Required!!!)</u></b></p>
	<p>10-24 x 1/2" Thumb Screw with Wing Nut</p>
	<p>1/4" x 2-1/4" Clevis Pin &amp; Hair Pin</p>
	<p>10-24 x 1/2" Thumb Screw with Hex Nut</p>
	<p>#12 x 1-1/2" Hex Screw</p>
	<p>#12 x 3/4" Self Drilling Screw with EPDM Washer</p>
	<p>#12 x 3/4" Self Drilling Screw</p>
	<p>Expansion Bolt (Concrete Anchor)</p>
	<p>#8 x 1/2" Self Drilling Screw</p>
	<p>#8 x 1/2" Self Drilling Screw with EPDM Washer</p>

## Tools Needed

Screw Gun

Metal Saw

Level

Clamps

Caulk Gun

1/2" Masonry Bit

Tape Measure

1/8" & 17/64" Drill Bits

Lubricant (Furniture Polish)

Marking Instrument

Pop Rivet Tool

1/4", 5/16", 3/8" and 7/16" Nut Driver Bits with Magnetic Heads

## Hardware Provided

Right & Left Mounting Rail End Cap

Sealer Tape (Peel & Seal)

## Component Descriptions

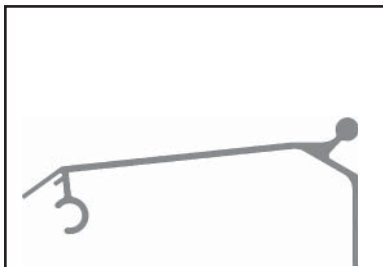

Mounting Rail

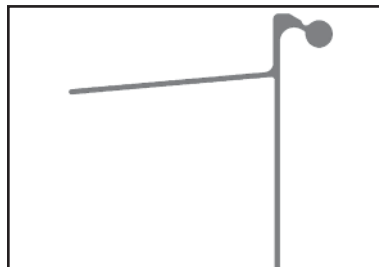

Dura-Fold Hinge

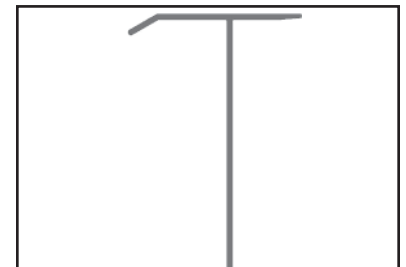

Side Fascia Trim

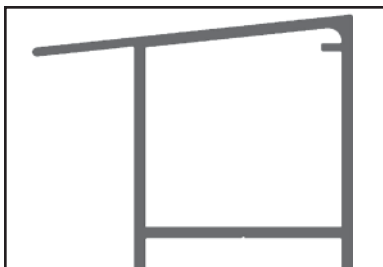

Deluxe Front Header



Deluxe Front Header Joiner

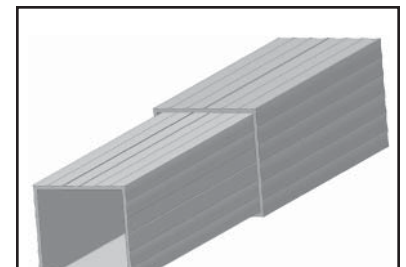

2" x 2" Dura-Post Column  
(Outer & Inner Posts)

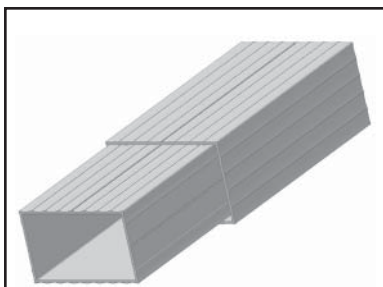

2" x 3" Deluxe-Post Column  
(Outer & Inner Posts)

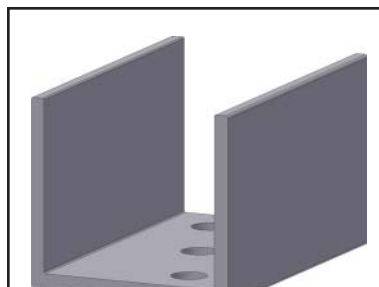

Anchor Bracket

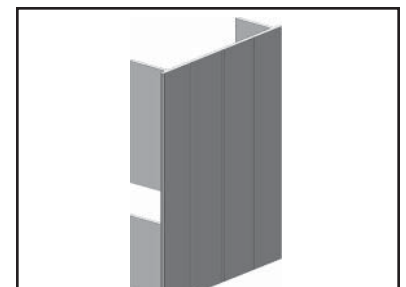

Deluxe Front Header End Cap

**Note: The Mounting Rail and Dura-Fold Hinge are marked Center, Left and Right.**

**Note: (Only Dura-Post uses Clevis Pin)**

## Component Descriptions

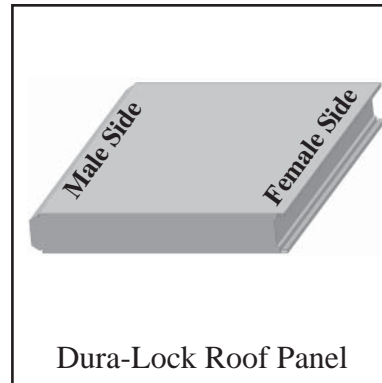
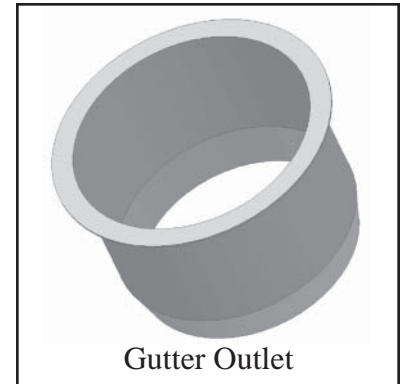
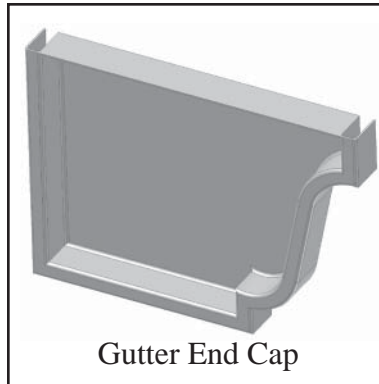
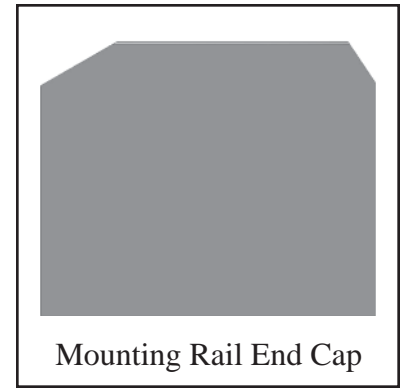
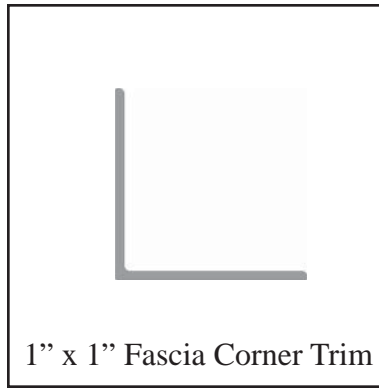
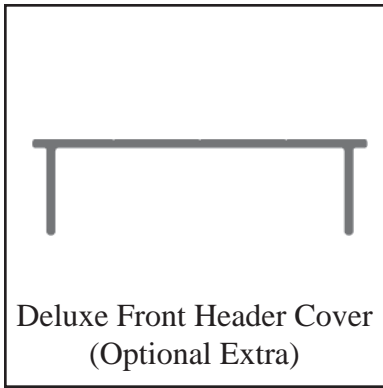

**Note: The gable end room cap will only be used if a room is being installed. The gable end room cap will be trimmed to fit and attached with #8 x 1/2 self drilling screws.**

Optional Extra: Post Anchor Assembly for Soil.

For wood anchoring use 4" x 4-1/2" Black Flashing with Paper coated adhesive on one side

# Getting Started

**Note: If you are going to install a Dura-Breeze under your Deluxe Dura-Fold Roof you must Install the roof first. If you are going to install any other room under your Deluxe Dura-Fold Roof, you should install the Mounting Rail and Hinge where you intend to locate your roof and room. Then you will install your room, then your roof panels.**

## 1. Preparing the RV Awning Rail for the Mounting Rail.

A. If your RV does not have a factory installed awning rail or yours is badly damaged, it is necessary to install a new one.

B. Make sure the Awning Rail is clear of dirt and debris , it may be necessary to loosen the fasteners along the awning rail. This will allow you to slide the Mounting Rail on easier. Leave fasteners loose until instructed to tighten.

2. References made to the left and right ends of the Awning are determined when viewed facing the RV.

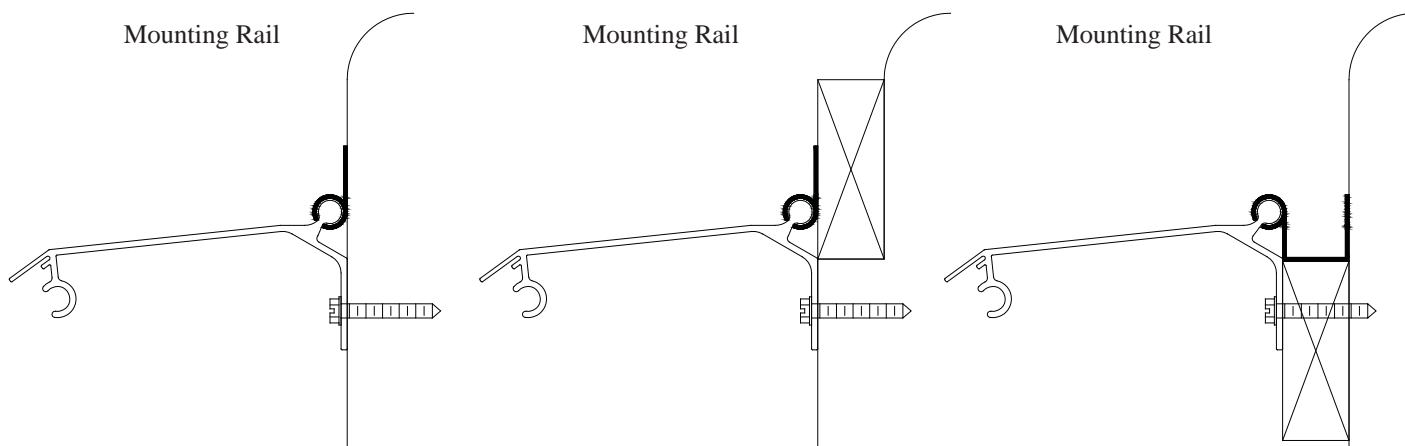

3. Because there are various styles of awning rails it may be necessary to shim either the RV Rail or the Mounting Rail. See examples above. Shim material is not provided with the Awning. **Caution!** Make sure when you are completed with this step that the Mounting Rail is below horizontal or water will run back to RV wall and cause leaking.

# Mounting Rail Installation

1. Determine where the Dura-Fold Awning is to be positioned along the RV awning rail and mark that location on the awning rail.

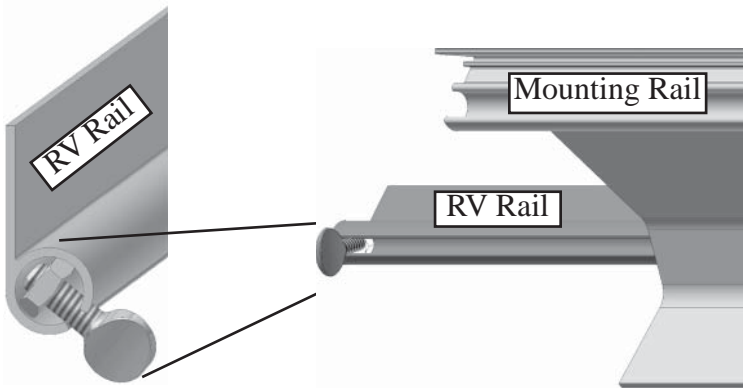

Install 1/2" thumb screw and nut into RV rail. Slide thumb screw to the left end position, mark and tighten. This will stop the Mounting Rail at the proper location.

**Note:** If you plan to add a Dura-Breeze Screen Room under the awning, you must position the awning so that the side walls of screen room will **not** join the RV at a window location.

2. Before sliding the Mounting Rail into the awning rail, spray the awning rail cavity with a lubricant such as furniture polish.



3. Each Mounting Rail section is labeled for order of assembly.

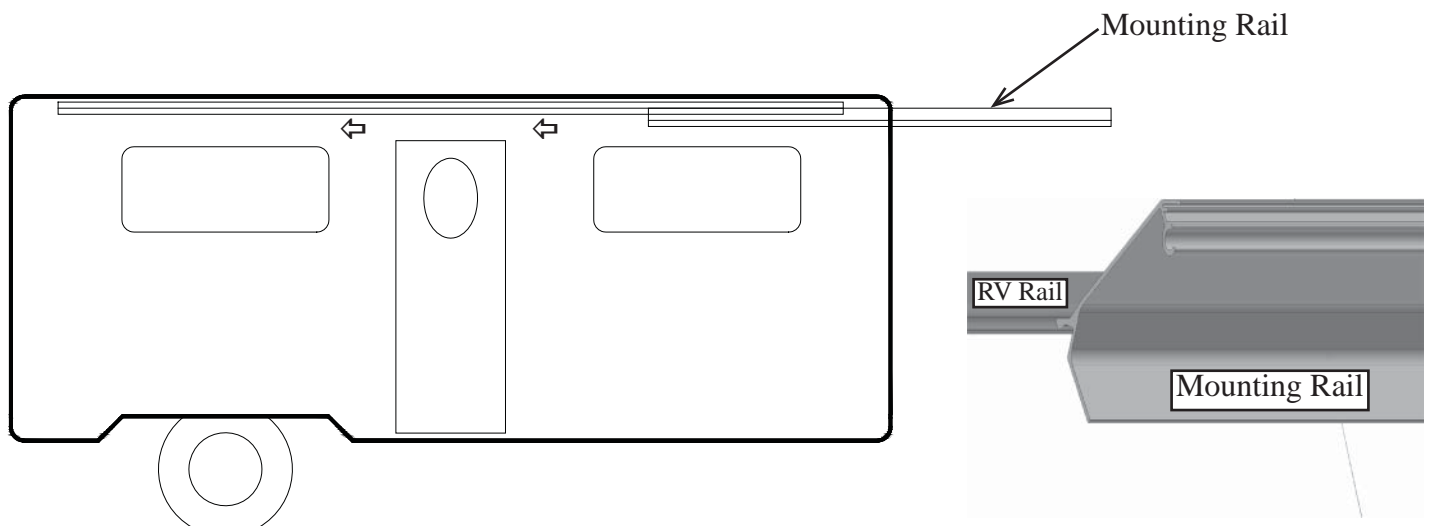

4. Slide the Left End of the Mounting Rail section into the RV awning rail until it reaches the thumb screw stop you installed.

5. Using the same procedure, install the remaining sections of Mounting Rail in sequence.

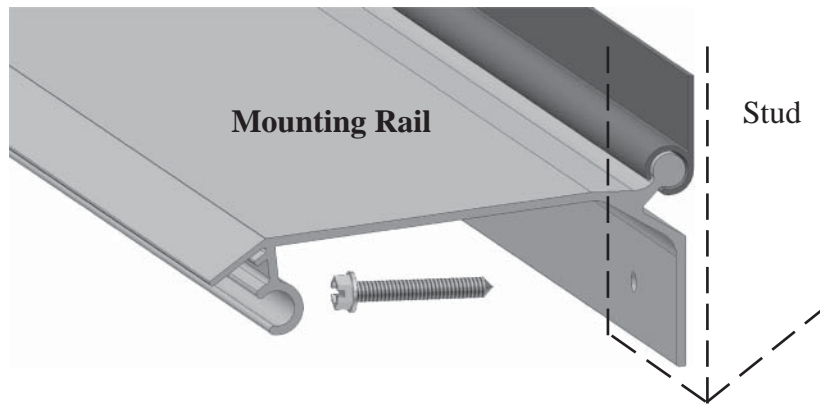

6. Secure the Mounting Rail to the side of the RV with #12 x 1-1/2" screws. Mark the locations of all studs or solid support on the bottom lip of the Mounting Rail. Drill 7/32" holes through your marks on the Mounting Rail. Lift the Mounting Rail and Caulk the back of the Mounting Rail before you Install #12 x 1-1/2" screws. **If you must shim the Mounting Rail, you should replace the #12 x 1-1/2" screws provided with new screws of an appropriately longer length.**

**Note:** As you slide each Mounting Rail section into position, make sure legs of the Mounting Rail Joiner straddle the Rail already in place.

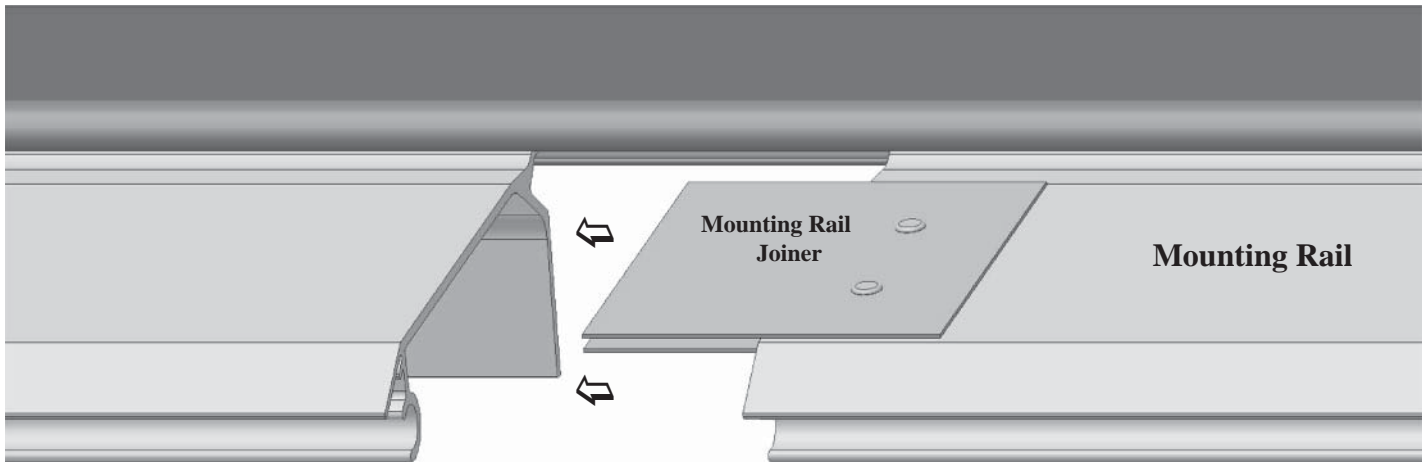

7. If you loosened any fasteners in the RV Rail, tighten them now. First, apply a generous bead of caulking in the cavity between the RV Rail and the side wall of the RV. Also caulk full length of top of the joint of the Mounting Rail and the RV Rail.

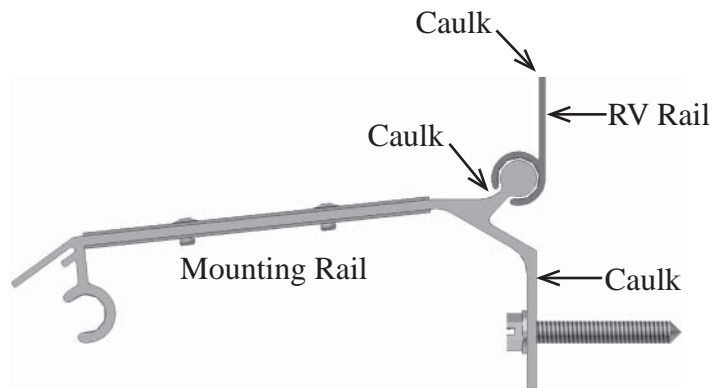

## Dura-Fold Hinge Installation

1. Lubricate the cavity of the Mounting Rail with furniture polish to allow the Dura-Fold Hinge to slide easier.

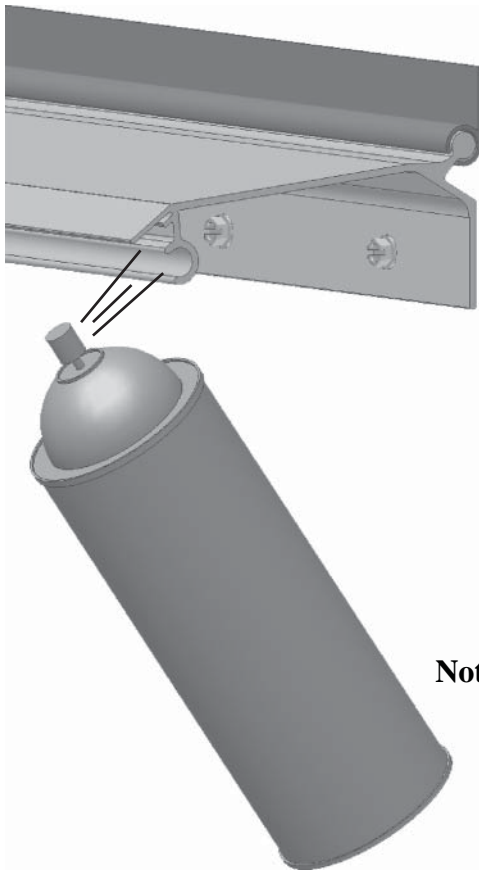

2. Working from the right side slide the Dura-Fold Hinge marked **Left** into the Mounting Rail, followed by the **Center** and the **Right**. Make sure you line up the Dura-Fold Hinge Joiners.

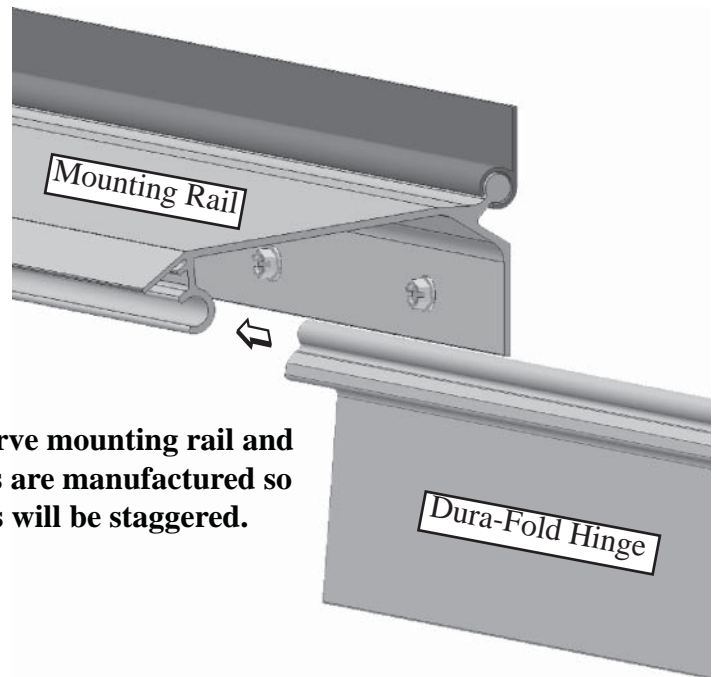

**Note:** You will observe mounting rail and hinge sections are manufactured so that the joints will be staggered.

3. Use a pair of Duckbill ViseGrips to hold the Dura-Fold Hinges together. Pre-Drill a 1/8" hole thru the Joiners and Hinge and install a #8 x 1/2" Self Drilling Screw.

**Note:** Make sure the screw fastens all three components together.

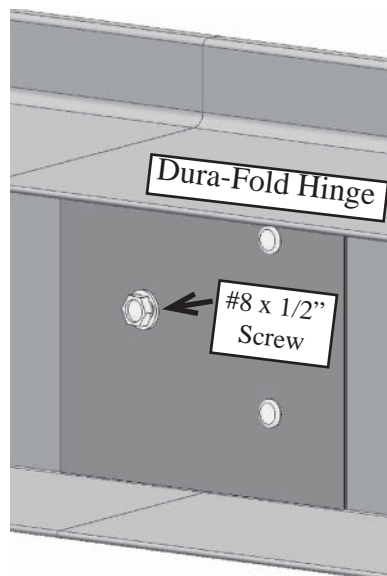

## Deluxe Front Header

1. Layout the Deluxe Front Header Section(s) on the ground.

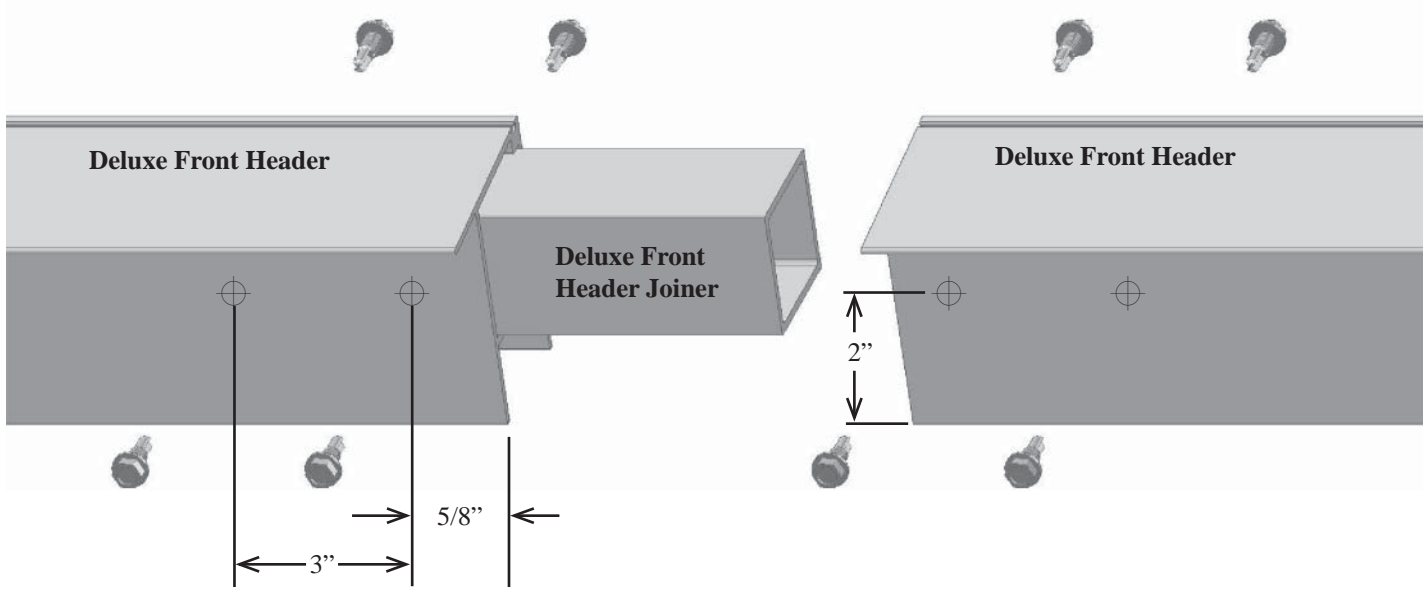

2. Insert the Deluxe Front Header Joiner 4-1/4" into the Deluxe Front Header.
3. Secure in place with four (4) #12 x 3/4" Self Drilling Screws.
4. Insert opposite end of Deluxe Front Header Joiner into next section of Deluxe Front Header and secure as in step #3.
5. Continue this same process with remaining Deluxe Front Header Sections.

## Deluxe Post Columns or Dura-Post Columns

(Only Dura-Post uses Clevis Pin)

1. Determine Post spacing using the chart on the next page.  
Then mark the location of each Post on the front and back leg of the Deluxe Front Header.
2. Measure up 1/2" from the bottom leg of the Deluxe Front Header on both sides and mark the Deluxe Front Header to be drilled.
3. Use a 17/64" drill to drill thru one side of the Deluxe Front Header at a time. You will have to do the same to the Deluxe Inner Posts.
4. Measure down a 1/2" in the center of the post and use a 17/64" drill to drill thru one side of the Deluxe Inner Post at a time.
5. Install a 1/4" x 2-1/4" Clevis Pin & Hair Pin thru the Deluxe Front Header and Inner post.
6. #12 x 3/4" Self Drilling Screws will be used for the height adjustment of the Roof by using (4) Screws on the Post.

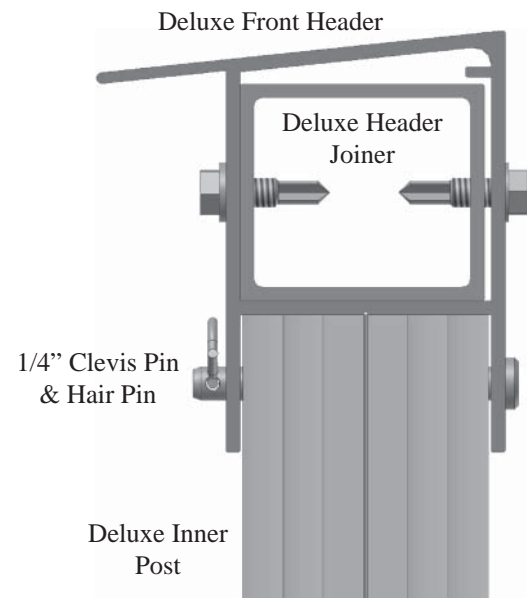

**Note: The recommended overhang of the Roof Panels at the Deluxe Front Header should be from 6" Min. to 18" Max..**

## Deluxe Dura-Fold and Dura-Breeze Post Spacing

**Note:** If you are just going to install a Deluxe Dura-Fold Roof with no intention of installing a Dura-Breeze Room underneath, then you should use the post spacing chart on the next page. If you are going to install a Dura-Breeze Room, spacing from Center Line of post to Center Line of post **MUST BE** as shown in the drawing below.

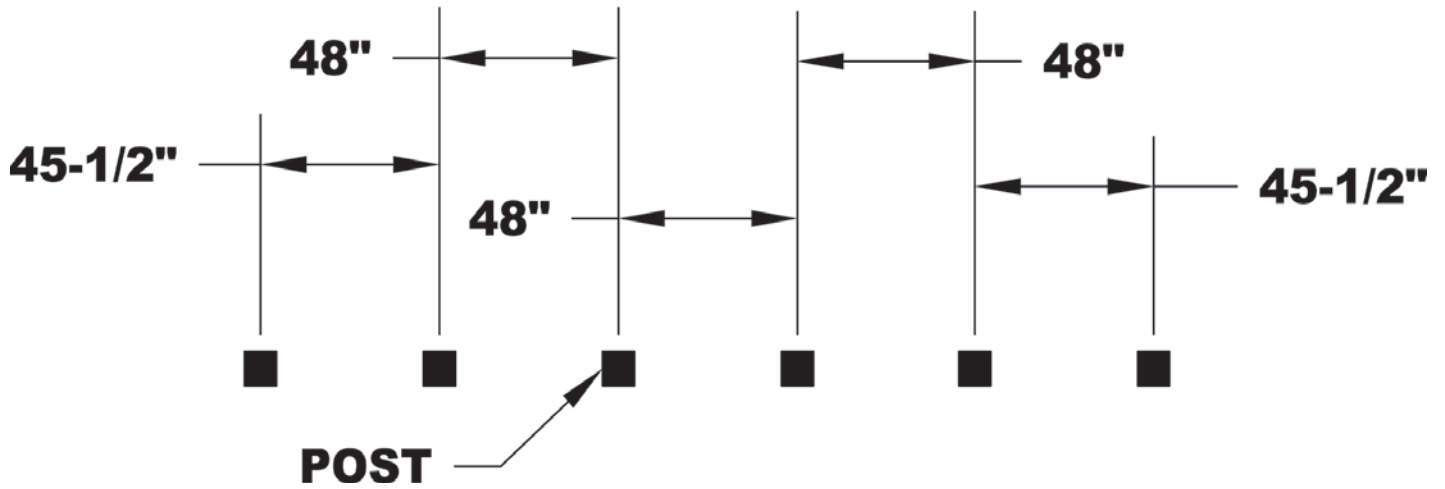

**Note:** Wall Heights are offered in 82", 90" and 96" from the floor to the bottom of the Deluxe Front Header.

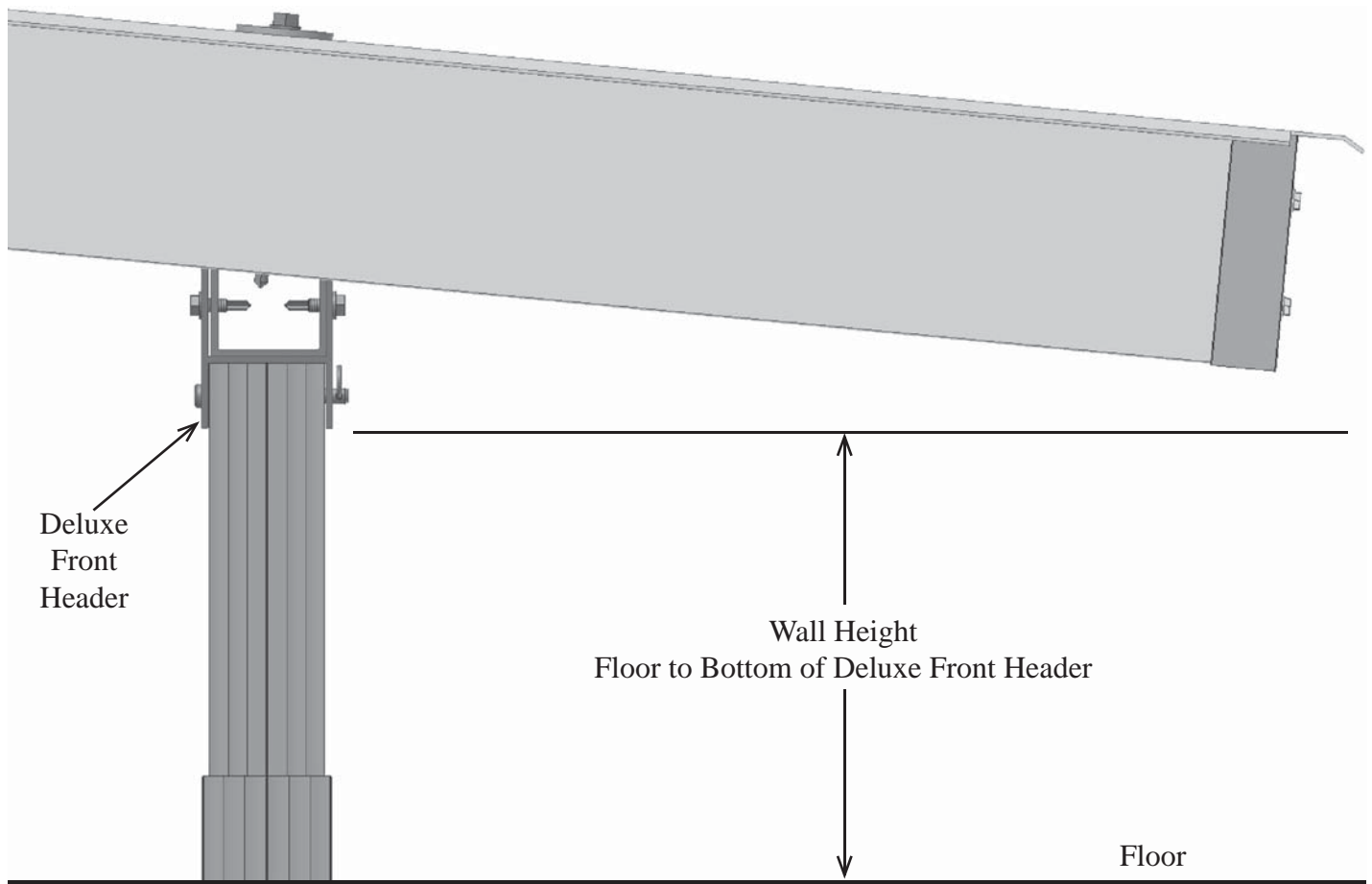

# Deluxe Post Columns or Dura-Post Columns

## Continued

4. Determine post length and then pull out post section to that length. Use a “C” Clamp to clamp inserts after wrapping with a piece of cardboard to protect the painted surface.

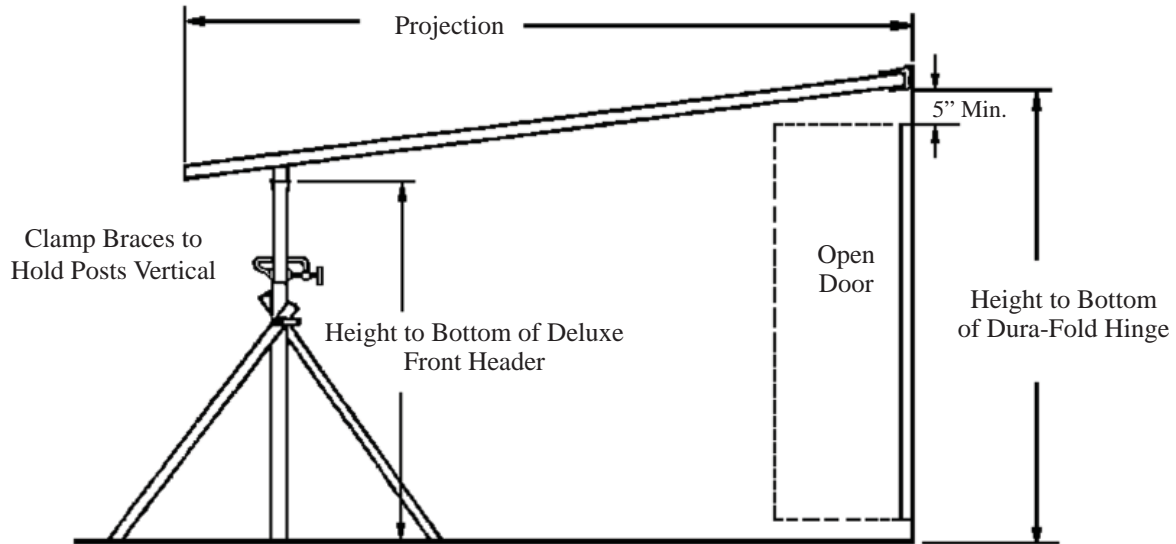

## Column Spacing Chart

Columns at the corners are to be set in 12” on-center from each corner

Roof Length	Number Columns	Spacing On-Center	Roof Length	Number Columns	Spacing On-Center	Roof Length	Number Columns	Spacing On-Center
4	2	2'	27	6	5'	51	10	5' 5-3/8"
5	2	3'	28	6	5' 2-3/8"	52	10	5' 6-5/8"
6	2	4'	29	6	5' 4-3/4"	53	10	5'-8"
7	2	5'	30	6	5' 7-1/4"	54	10	5' 9-3/8"
8	2	6'	31	6	5' 9-5/8"	55	10	5' 10-5/8"
9	3	3'-6"	32	6	6'	56	10	6'
10	3	4'	33	7	5'-2"	57	11	5'-6"
11	3	4'-6"	34	7	5'-4"	58	11	5' 7-1/4"
12	3	5'	35	7	5'-6"	59	11	5' 8-3/8"
13	3	5'-6"	36	7	5'-8"	60	11	5' 9-5/8"
14	3	6'	37	7	5'-10"	61	11	5' 10-3/4"
15	4	4'-4"	38	7	6'	62	11	6'
16	4	4'-8"	39	8	5' 3-3/8"	63	12	5' 6-1/2"
17	4	5'	40	8	5' 5-1/8"	64	12	5' 7-5/8"
18	4	5'-4"	41	8	5' 6-7/8"	65	12	5' 8-3/4"
19	4	5'-8"	42	8	5' 8-1/2"	66	12	5' 9-3/4"
20	4	6'	43	8	5' 10-1/4"	67	12	5' 10-7/8"
21	5	4'-9"	44	8	6'	68	12	6'
22	5	5'	45	9	5' 4-1/2"	69	13	5'-7"
23	5	5'-3"	46	9	5'-6"	70	13	5'-8"
24	5	5'-6"	47	9	5' 7-1/2"	71	13	5'-9"
25	5	5'-9"	48	9	5'-9"	72	13	5'-10"
26	5	6'	49	9	5' 10-1/2"	73	13	5'-11"
			50	9	6'	74	13	6'

## Roof Panel Installation

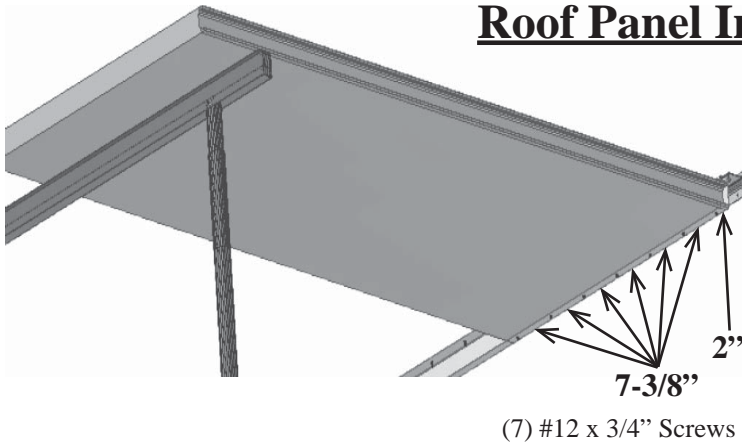

1. Insert the first panel into right end of the Dura-Fold Hinge. The Panel's female edge must be on the right.

2. Square Roof Panel in the Dura-Fold Hinge, making sure it's fully seated. Then secure with (7) #12 x 3/4" Self Drilling Screws from the under side of the Dura-Fold Hinge. Start the first screw 3/4" back from the front lip and 2" in from right side edge of Roof Panel and spaced at 7-3/8".

**Helpful Hint: Protect Roof Panels from being scratched by placing a piece of cardboard from product carton over the Deluxe Front Header.**

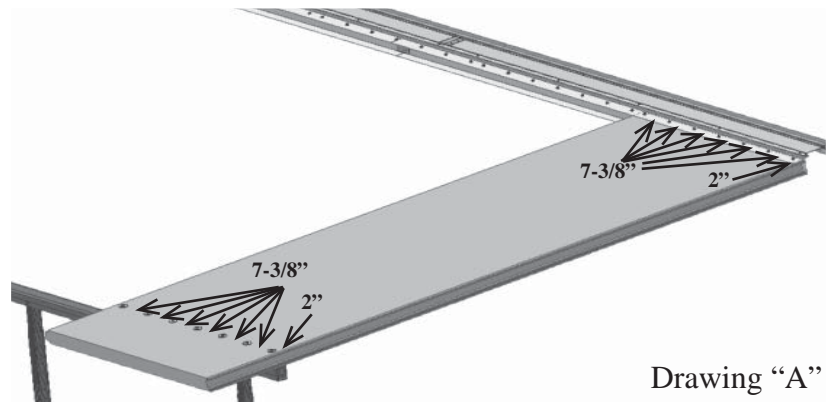
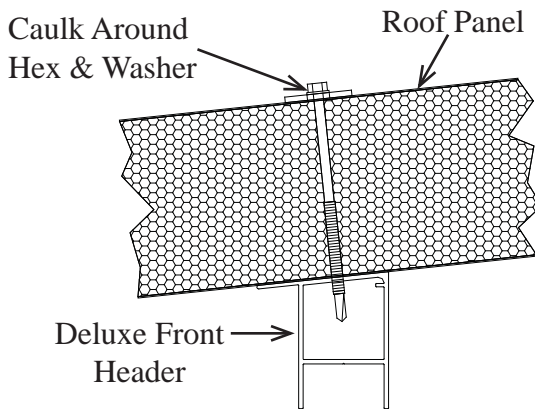

**IMPORTANT Do Not Over-Tighten the Screws.** If you tighten to the point where the Roof Panel is depressed, even if the screw is backed out, the Roof Panel will NOT return to its original flat surface. Drive screws until tight to panel, but not depressing the surface of the panel.

**Note:** If you are installing a Dura-Breeze Screen Room, Deluxe Front Header must be located to accommodate room width. Dura-Breeze Rooms are offered in widths (Home to front wall of room) of 8', 10' or 12'.

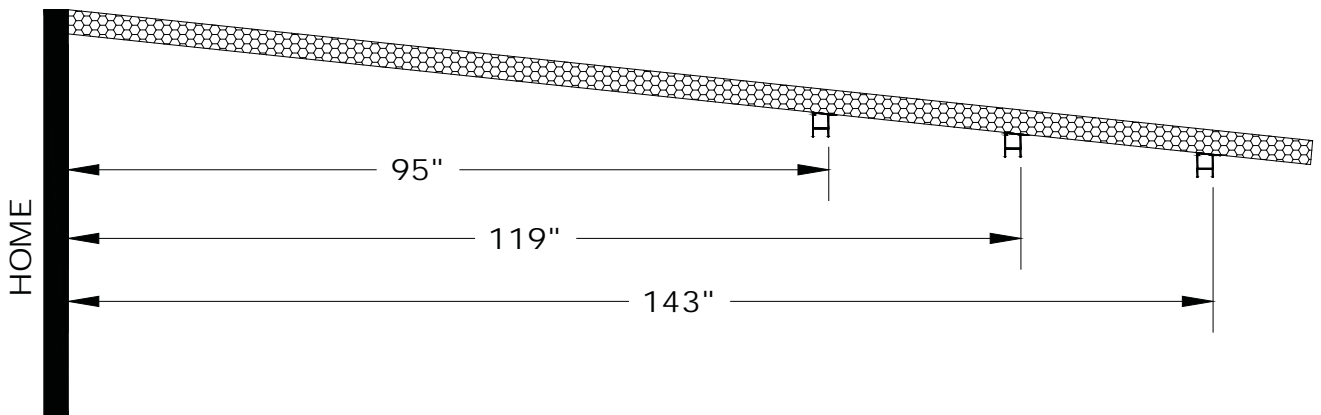

4. With the Roof Panel square in the Mounting Rail and on the Deluxe Front Header, strike a chalk line on top of the Roof Panel to mark the location for fasteners so they will go down through the center of the Deluxe Front Header. Slide your cardboard protector down the Deluxe Front Header before installing fasteners into Deluxe Front Header.
5. Secure Roof Panel to the Deluxe Front Header with (7) #14 x 4" Self Drilling Screws and 1-1/2" EPDM Washers per panel. The first fastener should be 2" in from right side of Roof Panel and through your chalk line. See screw spacing in **Drawing "A"**. **Do not install last screw into Header on front edge of panel.** This will allow enough "lift" so that the next panel can snap into position.

**Note:** Depending on the pitch of the roof you might have to use #14 x 5" Self Drilling Screws.

**Recommended Procedure:** Remove the wax coating on the Male Recess and the Sealant Press with a solvent before caulking. Run a thick bead of caulk down the entire male recess on top of the first panel and a thin bead down the entire female recess on the bottom of the next panel. Make sure there are no air bubbles or air pockets in the caulk. Repeat this procedure on all remaining panels.

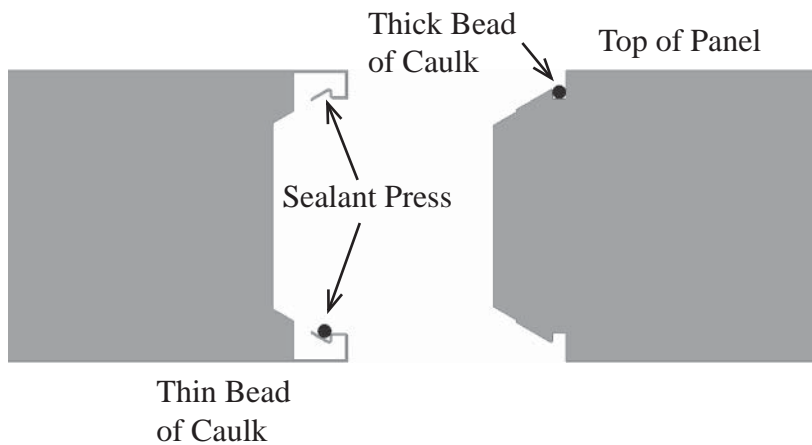

**Note:** If you are planning to take the Deluxe Dura-Fold Roof down in the future. Only run the thick bead of caulk down the top of the panel. Do Not put a bead of caulk in the lower Sealant Press.

7. Position second panel with female edge lined up with the male edge of the installed panel.  
**Note:** Step 1 Panel should be resting on Front Header and fully inserted into the Mounting Rail. Step 2 with panel in position, bump new panel into first panel until they snap together. See Drawing.

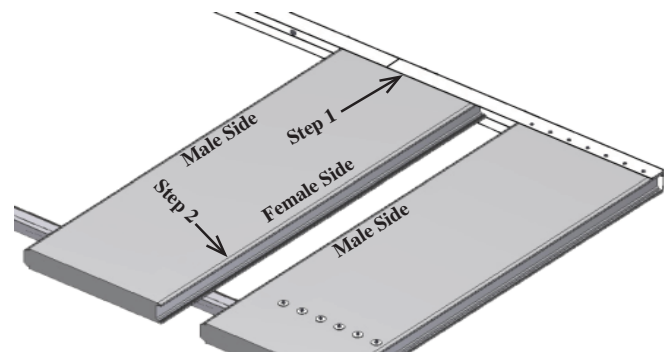

8. Smooth caulk on top, the length of the joint. Add caulk in low spots, if necessary.
9. Go back and install last screw in first panel into Front Header.
10. Secure new panel as in steps 4 and 5.
11. Repeat procedure until all panels are installed.
12. Before installing last panel, trim off the Male Interlock.



**If you are installing a fan beam, please note that the proper position is to have the beam cavity closer to the top of the panel rather than the bottom of the panel.**

## Roof Post Anchoring

1. Make sure Posts are plumb in both directions
2. Mark location for Anchor Brackets.

**Note: If you are installing Posts on a Pressure Treated Lumber Deck. With your order you will receive a 4" x 4-1/2" piece of Black Flashing with paper coated adhesive on one side for each Dura-Post and Deluxe Post. Peel the paper off from the Flashing and stick the flashing to the bottom of the Anchor Bracket. Then trim the excess Flashing from around the Anchor Bracket.**

3. Move Posts aside from marked locations and install Anchors.

**Note: You must use a 1/8" drill and pre-drill the holes for the fastener. Attach Bracket to wood with two (2) #14-10 x 2-1/2" Galvanized Hex Washer Head Screws. (Full Embedment Required!!!)**

**Note: If there is to be a Dura-Breeze installed under the roof you must turn the Anchor brackets 90 degrees so the fastener is parallel to the Deluxe Front Header.**

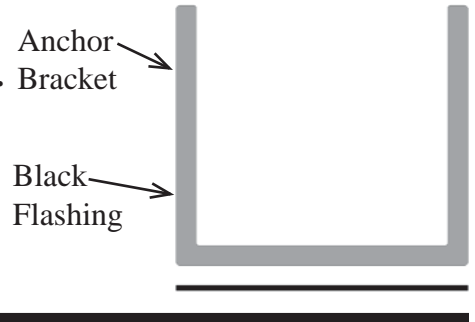
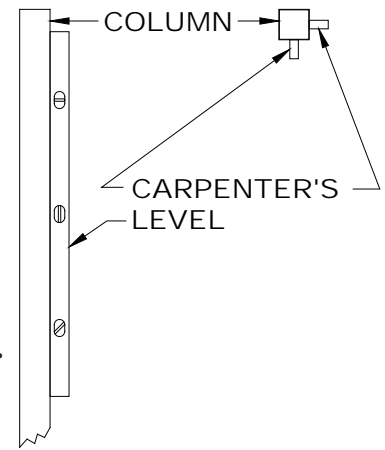

## Concrete Anchor Installation

1. Drill hole 1-7/8" deep with a 1/2" masonry drill bit. Insert Anchor Bolt, Expanding Ferrule, Lead Anchor and Washer.
2. Use hammer and 1/4" pipe to seat Anchor.
3. Place Anchor Bracket over Bolt and secure with 1/4" nut.

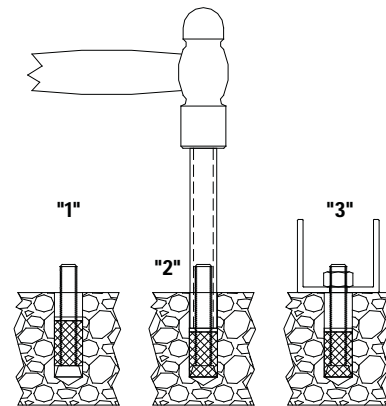

## Installing Post Anchor Bracket

1. In the center of the post measure up 1" from the bottom and use a 17/64" drill to drill thru one side of the post at a time.
2. Slide the Outer Deluxe Post over Anchor Bracket.
3. Use the same 17/64" drill and drill thru the Anchor Bracket using the Outer Deluxe Post as a guide.
4. Secure Post to Anchor Bracket with a 1/4" x 2-1/4" Clevis Pin & Hair Pin.

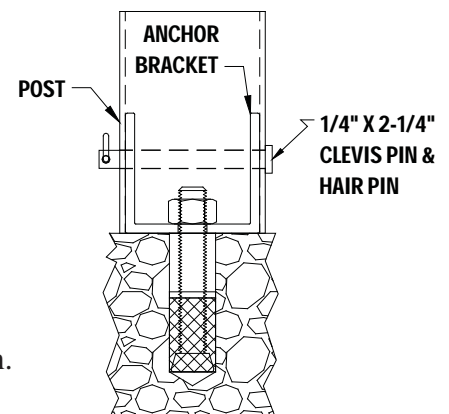

## Leveling

1. Place carpenter's level on underside of Deluxe Front Header.
2. Adjust Inner Post to level the Deluxe Front Header.
3. Secure with four (4) #12 x 3/4" Self Drilling Screws.

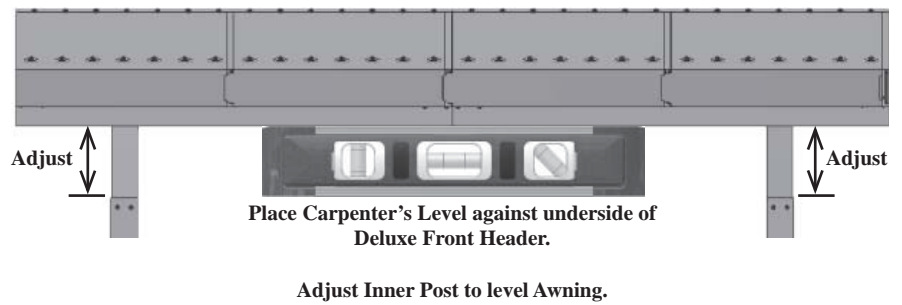

## Front & Side Fascia

1. Install Front & Side Fascia on the front and sides of Roof.
2. The two side pieces will be 4" longer than the actual projection of the Awning.
3. The remaining pieces will be 4" longer than the Awning length. This extra length provides enough material to miter the corners.
4. Cut Front & Side Fascia straight to overlap the corner or at 45° miter for a finished corner look.

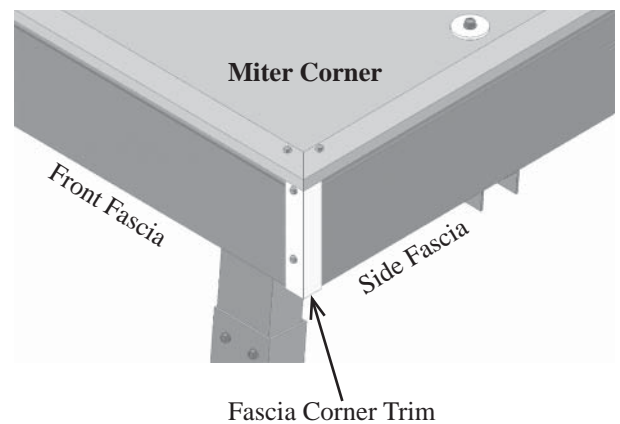
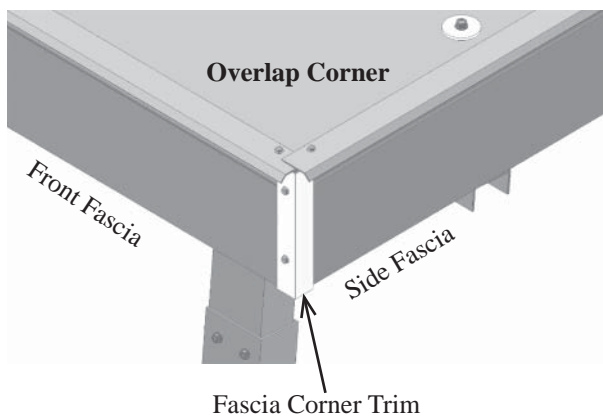

5. Before installing Front and Side Fascia, apply a small bead of caulk on top of Panel, 1/2" in from edge. Slide the Fascia onto the Panel. Secure to Panel with #8 x 1/2" Self Drilling Screws, spaced 18" apart, installed through both the top and bottom lips of the Front and Side Fascia.
6. Measure and cut the Fascia Corner Trim to fit as shown above. (It is shipped in one piece; 1" x 1" x 14"). Attach to Front and Side Fascia with two (2) #8 x 1/2" Self Drilling Screws as shown.

## Finish Roof Attachment

1. Finish attaching the Roof Panels to the Dura-Fold Hinge by using (7) #12 x 3/4" Self Drilling Screws with EPDM Washers per Roof Panel down thru the top of the Dura-Fold Hinge. The Screws should be positioned 2" in from right, then every 11" and 1-1/2" back from the front lip of the Dura-Fold Hinge. **Important:** The screws need to be 1-1/2" back from the front lip of the Dura-Fold Hinge to give clearance for the Flashing. See Drawing below.

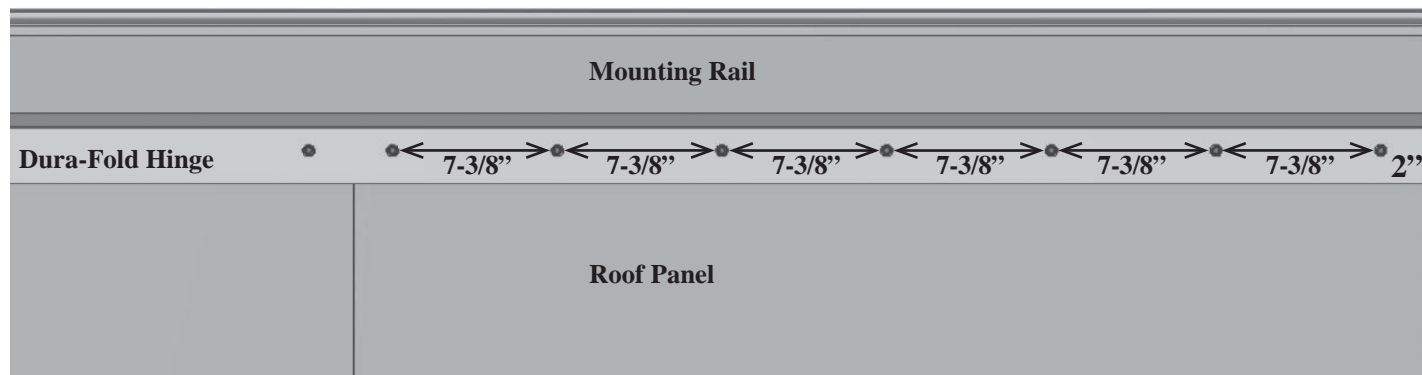

## Install Flashing

1. Mounting Rail Flashing is provided in 6" x 121" sections. Start the Flashing at the right of the roof by pushing it up into the Flashing slot of the Mounting Rail. Install your first #8 x 1/2" screw 1" in from the right end; every 24" after that. Make sure you overlap the first piece of flashing with the next piece of Flashing by 1" and secure with #8 x 1/2" screw. Try to avoid ripples by working the Flashing from the right to the left.

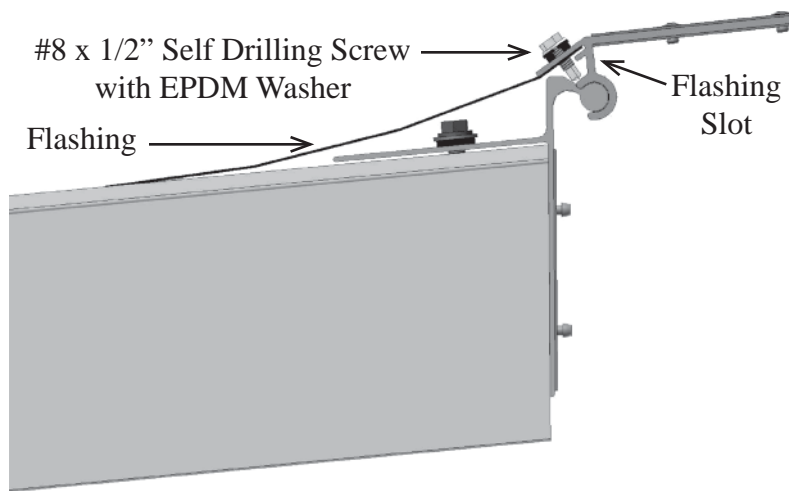

## Apply Sealer Tape (Peel & Seal)

1. After all Roof Panels are installed, apply Sealer Tape. Remove film covering the black, sticky surface. Apply over the center of each joint; covering flashing, Mounting Rail, Mounting Rail Joiner and continuing over the bead of RV Rail. Make sure that tape adheres to all surfaces.

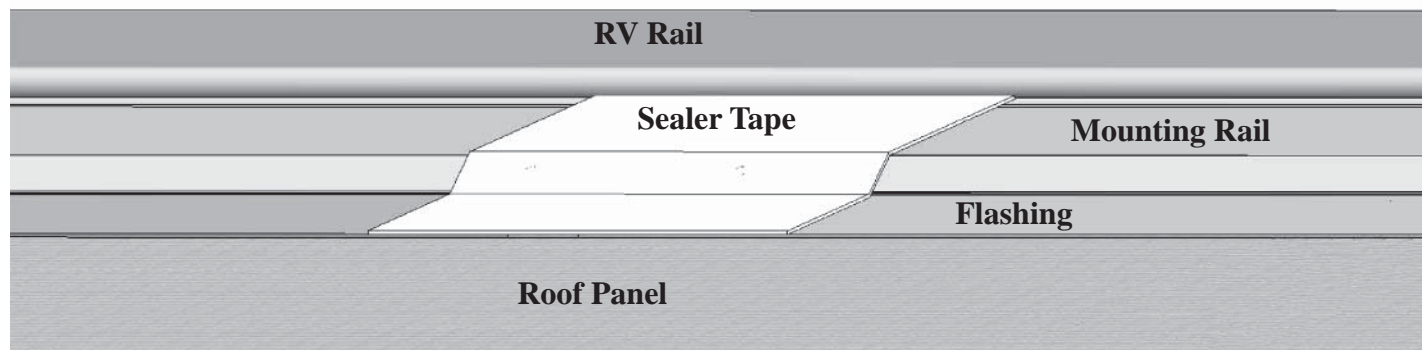

## Install Mounting Rail End Caps

1. Line up the Mounting Rail End Cap and trim it to fit.
2. Use the trimmed End Cap as a template and drill a 3/16" hole thru the Mounting Rail.
3. Attach End Cap to Mounting Rail with 1/2" Thumb Screw and Wing Nut.
4. Repeat steps 1 thru 3 for the other End Cap.

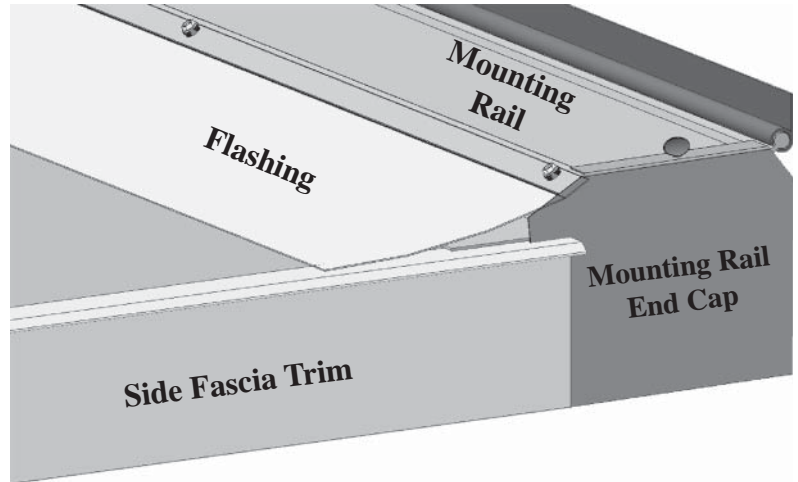

## Installing Gutter

(Gutter is shipped in lengths of: 16'-3", 12'-3", 10'-3" and 5'-3")

1. Decide where downspouts will be located. This will determine where the Outlets will be installed in the gutter.
2. Mark gutter where the Outlets are to be installed. The round Outlets will allow the elbows to be rotated to any position you want.
3. To install Outlet, cut a 2-3/8" round hole centered in the bottom of the gutter. Then simply push Outlet down through gutter until it snaps into position. No caulk, screws or rivets are required to install the Outlet in the gutter.
4. If you have gutter sections to be joined, it is recommended to do it while on the ground.

The sections may be joined by one of the following methods.

### Method #1

Use the Gutter Joiner provided. Caulk ends of gutter, then slide gutter sections into the Joiner seams. Pop Rivet the joints where shown. Then smooth caulk in the seams of Joiner and gutter.

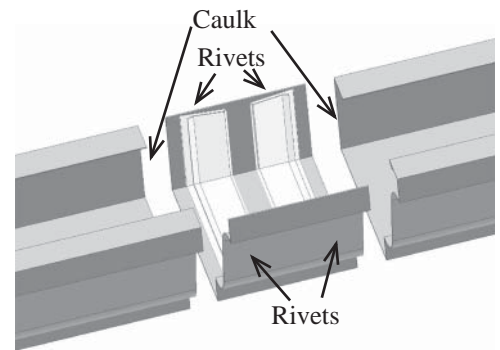

## Method #2

Cut a 2" notch in front and back walls of gutter as shown. Caulk the section not notched. Then slide the notched section inside the caulked section. Install Pop Rivets in bottom and each side.

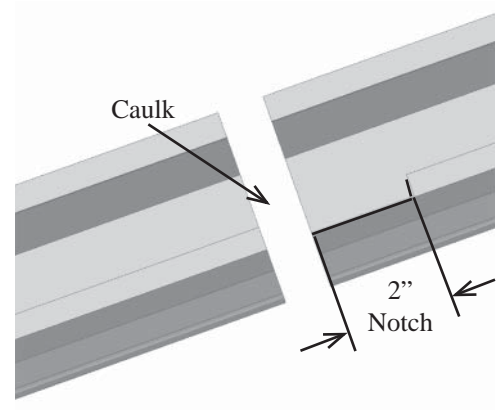

**Helpful Hint:** For a professional looking installation, make gutter cut-offs at the ends that will be hidden in the Joiner (Method #1) or inside another section (Method #2).

5. Install Hidden Gutter Hangers in the gutter. Locate your first hanger so that it will be at end of Fascia. See drawing.

Then install Hangers for the length of the gutter. Hangers should be no more than 24" apart. If you have joined gutter sections, you may have to move a Hanger a few inches to miss the joint.

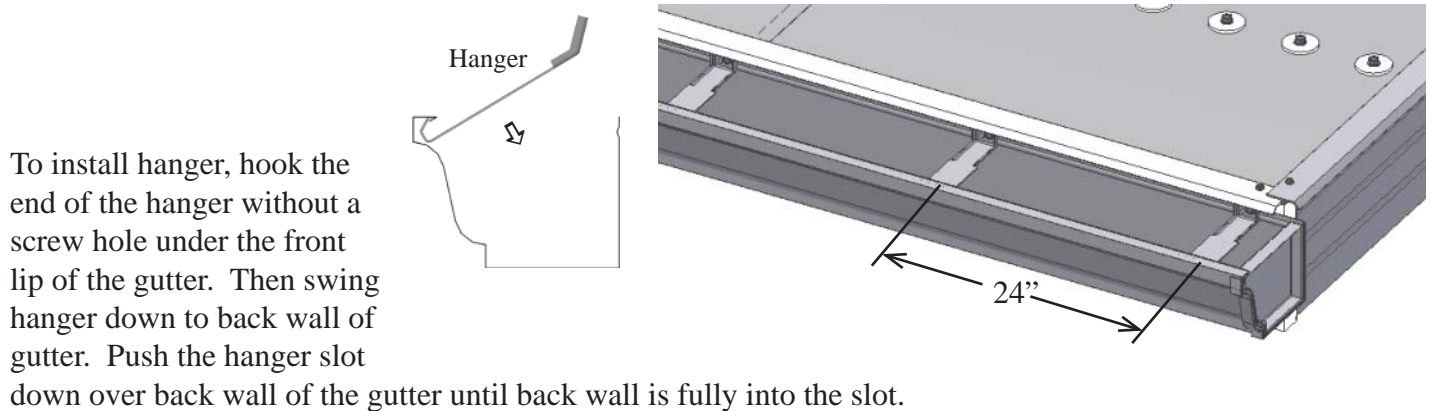

To install hanger, hook the end of the hanger without a screw hole under the front lip of the gutter. Then swing hanger down to back wall of gutter. Push the hanger slot down over back wall of the gutter until back wall is fully into the slot.

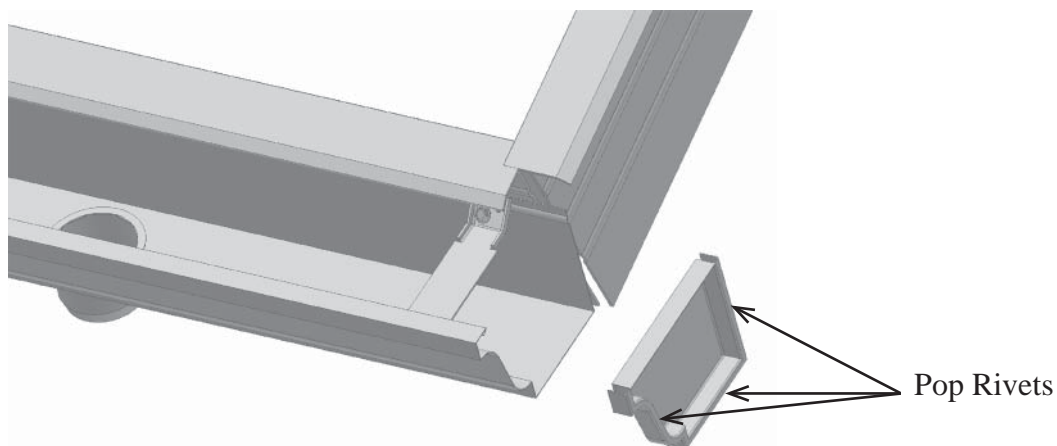

6. Install the End Caps. Caulk the end of the gutter. Install End Cap. Pop Rivet where shown.

## Hanging the Gutter

1. You must provide support for the gutter to hold it in position against the fascia. Starting at the center of the gutter, install a #12 x 3/4" Self Drilling Screw through the hole in the hanger and into the fascia. Continue until all hangers have been fastened.

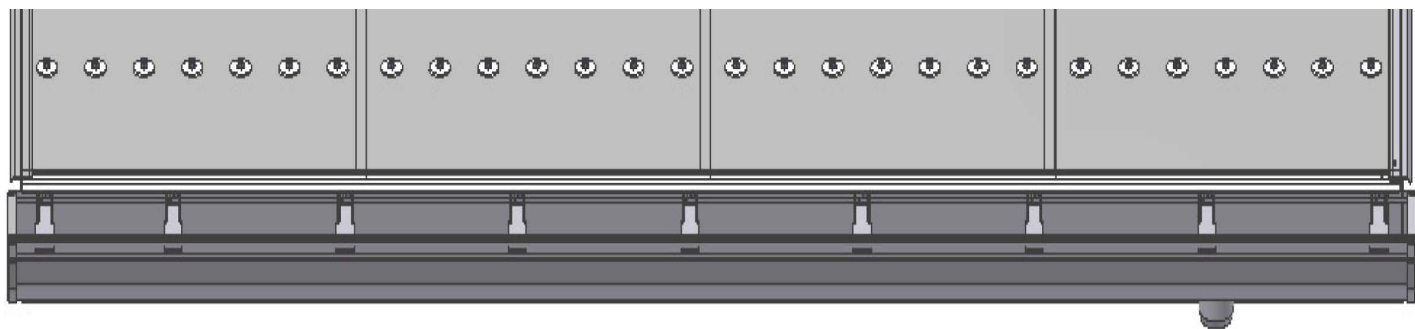

## Downspout Assembly

### **Downspout Leader**

Supplied in 8-foot length only. Cut to desired length using metal saw with fine tooth blade (24T).

### **Elbows**

When Elbows and Downspout Leader are fitted and in position---install two #8 x 1/2" screws at each joint.

### **Downspout Leader Straps**

Straps are supplied flat and are easily hand formed around the Downspout and fastened to Column.

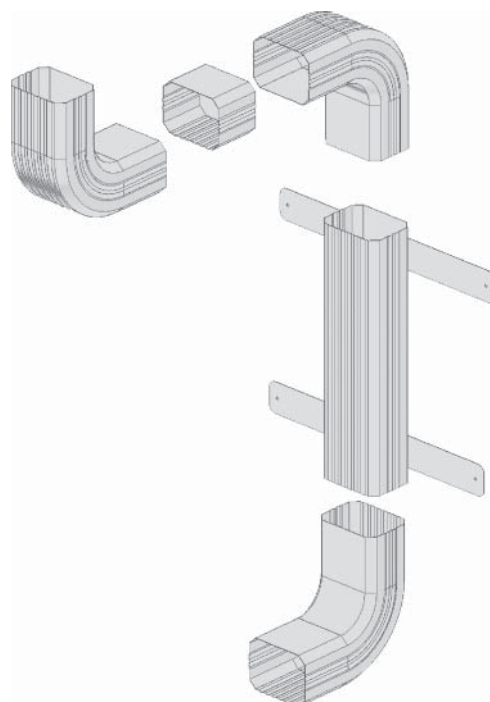



# DURA-BILT PRODUCTS, INC.

## Five Year Limited Warranty

Dura-Bilt Products, Inc. warrants its manufactured products to the original purchaser to be free from defects in materials or workmanship under the terms and conditions set forth herein. All other components and parts carry their own manufacturers warranties.

Within the warranty period, to be confirmed with copy dated bill of sale, Dura-Bilt Products, Inc. will, at its sole option, repair or replace any components which the owner has proven to have failed in normal use. Such repairs or replacement will be made, at no charge for parts, to the original purchaser. Provided, however, that the original purchaser shall be responsible for any transportation or freight costs. Replacement of materials does not extend original warranty period. This warranty does not include the cost of labor for installation of parts.

Continuing product developments require that Dura-Bilt Products, Inc. retain the right to substitute replacement parts or components of equal quality, if necessary. Normal aging and weathering of materials may result in not being able to perfectly match the original colors.

This limited warranty does not cover failures due to weather, acts of God, abuse, misuse, improper installation, accident, alteration or repair. Dura-Bilt Products, Inc. assumes no responsibility for special, incidental, punitive or consequential damages or loss of use.

**THIS LIMITED WARRANTY IS EXCLUSIVE AND IN LIEU OF ALL OTHER WARRANTIES AND REMEDIES EXPRESS OR IMPLIED, INCLUDING ANY LIABILITY ARISING UNDER THE WARRANTY OF MERCHANTABILITY OR FITNESS FOR A PARTICULAR PURPOSE, STATUTORY OR OTHERWISE. THIS WARRANTY GIVES YOU SPECIFICALLY THESE RIGHTS WHICH MAY VARY BY STATE.**

This warranty covers products manufactured by Dura-Bilt after 9/1/95.

To obtain warranty service, call the Dura-Bilt Products Customer Service Department at 1-570-596-2000 or write to P.O. Box 188, Wellsburg, NY 14894-0188. Retain this Warranty for your records.