

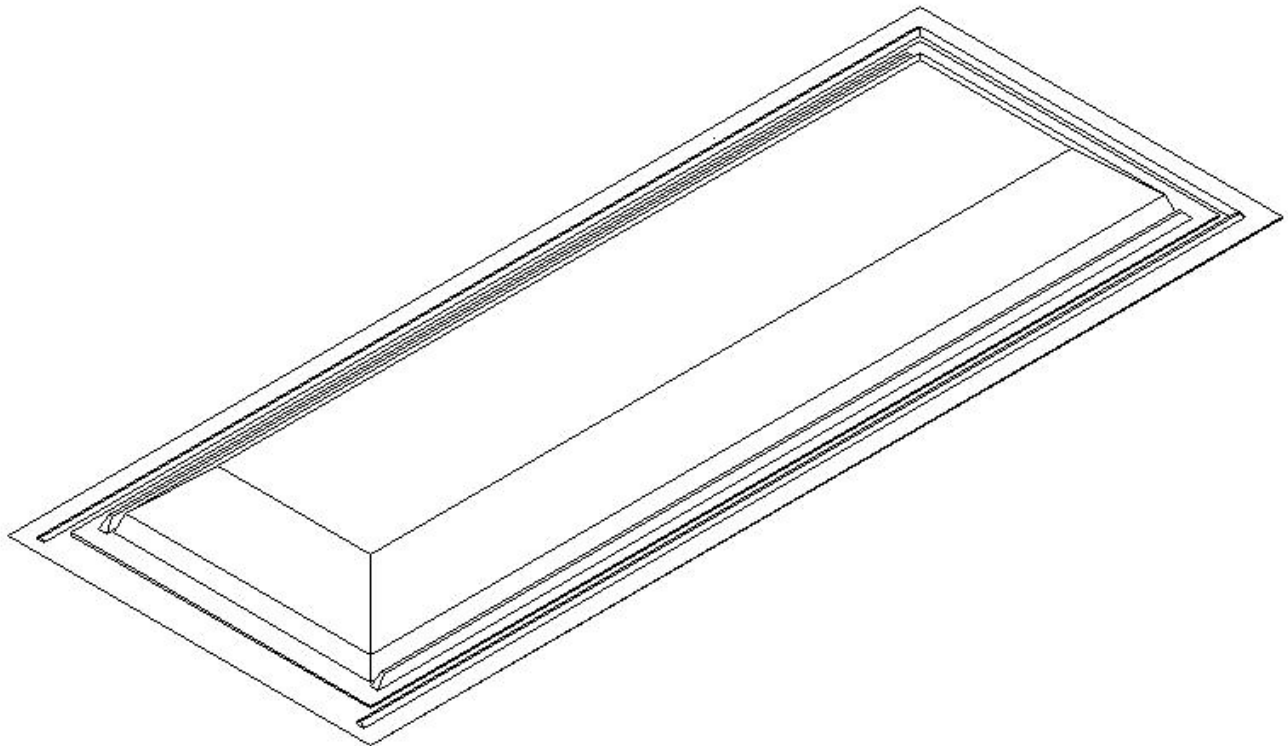

2" DURA-THERM FIXED SKYLIGHT

Field Installation Instructions

Read instructions before starting the job. They explain the steps required to produce a finished product that will meet factory specifications. **All references to "Left and Right" are while facing the home.**



Check the material received.

Match your shipment with the bill of Materials.
If there is a shortage or wrong material, call Dealer Service immediately.

Safety is Important!

Wear Safety Glasses and Work Gloves.
Follow all safety practices while assembling and installing this product.

DURA-BILT PRODUCTS, INC. P.O. Box 188 Wellsburg, N.Y. 14894
Dealer Service 1-570-596-2000 E-Mail info@durabilt.com
DURA-BILT RESERVES THE RIGHT TO CHANGE DESIGN AND/OR SPECIFICATIONS WITHOUT NOTICE.

Component Descriptions

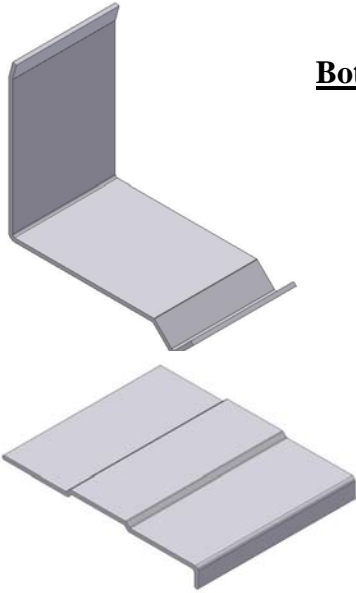

Bottom Framework: Trims off the skylight opening on the underside.

Top Framework: Trims off the skylight on the top.



Screw assembly: Attaches skylight to roof panel.

(4) Layers of .045" thick X 1" wide 3M VHB Foam Tape: Apply to outside perimeter of hole.

1/8" X 1-1/2" Gray Adhesive Tape: Apply to outside perimeter of Foam Tape.

Pop Rivet: Standard 1/8" aluminum Pop Rivet.

Skylight:

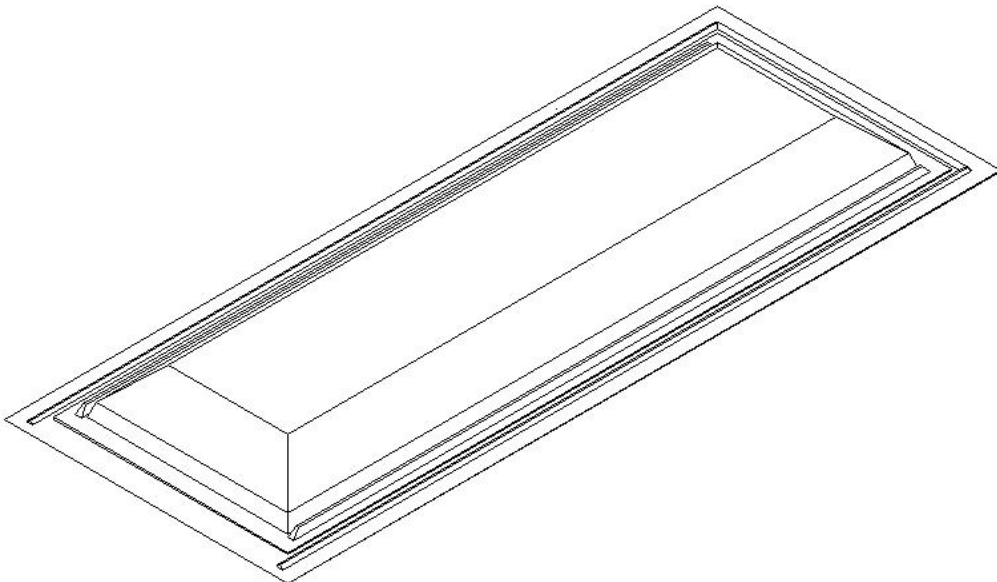

Skylight Installation

- 1) Cut hole in roof panel: 14-1/2" X 46-1/2".
- 2) Take bottom aluminum framework and use pop rivets to attach framework to underneath side of panel.

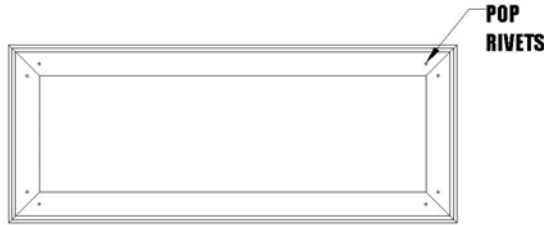

- 3) Lay skylight on top side of opening (**CENTER OVER OPENING**) make sure air outlet is facing gutter. **Do not** use caulk or adhesive tapes anywhere during this step.
- 4) Lay the Top Aluminum Framework over the skylight and trace around Framework with a pencil on the panel. Drill holes with a #3 or 7/32" drill bit. Drill through center rib of the Top Framework completely through the Skylight and the Bottom Framework on all four sides. Diagram below shows the spacing of the holes.

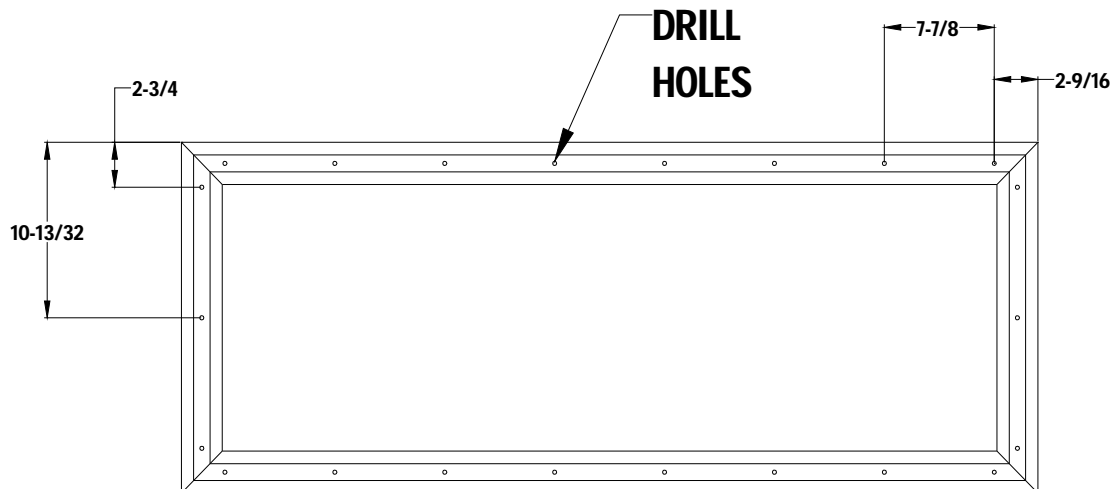

- 5) Remove top aluminum framework and skylight. After cleaning the top panel surface around the edge of the opening with a 50-50 mixture of isopropyl alcohol and water, use **(4) Layers of .045 thick X 1" wide Foam Tape** and position it around the perimeter in a **staggered overlapping** fashion on the roof panel **Next** to the hole opening.

HELPFUL HINT: Roll the first layer of tape, and then remove the protective paper to apply the remaining layers. They also must be rolled. Care must be used because the tape will not come apart!!! This also applies to placing the skylight to roof panel!!!

- 6) Take **1-1/2" Gray Adhesive Tape** and apply it **Along Side** the outside perimeter of existing Foam Tape.
- 7) Lay a bead of caulk approximately 1/8" inside of the Top Framework pencil line.

- 8) Now take the skylight and lay it over the opening and the foam and rubber tape. Carefully position it to **Line up with Top Framework pencil tracing on panel.**
- 9) Now take top aluminum framework and place it around top perimeter of skylight, lining it up with pencil tracing on the panel. Apply a small amount of caulk in each hole in the top of the aluminum framework.
- 10) Prepare the screw assemblies for the binding post by putting these items on in the following order; hex nut, white plastic washer with indented side toward the nut, stainless washer with black neoprene. Thread nut nearly to top of screw.

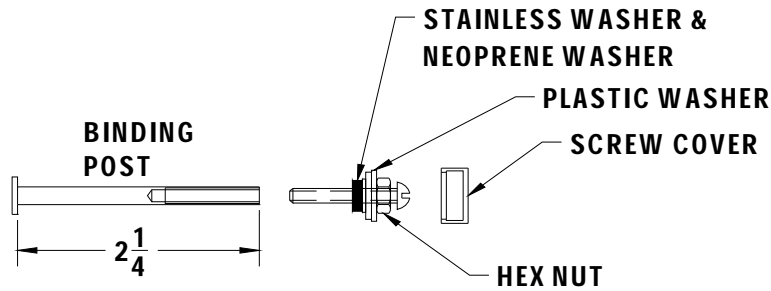

- 11) Then insert binding post from the bottom of the skylight framework. Insert screw into binding post and turn until it reaches the bottom of the threaded portion of the post. Tighten nut securely. Then cut top of the screw off just above the nut. This will allow you to install the screw cover.
- 12) Apply caulking around the perimeter of the top framework where its edge meets the skylight "Bubble". Then apply caulking around the outside perimeter of the top framework where its edge meets the roof panel.

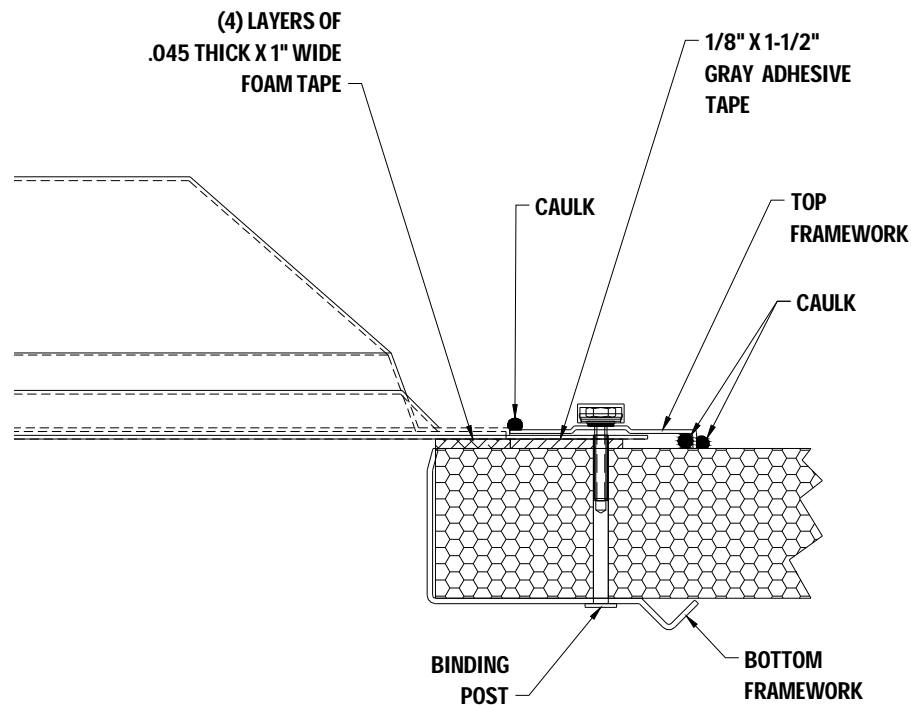

- 13) Also apply caulk on the Top Framework miter joints.