



Assembly Instructions

for the In-Swinging Door

Deluxe 3-Season Sunroom, Standard 3-Season Room, Deluxe Screen Room and Full Screen Room Installation of the Handle, Latch, Deadbolt & Closer



Read the instructions before starting the job. They explain the steps required to produce a finished product that will meet factory specifications.

All references to “Left” and “Right” are while facing the home.

Check the material received.
Match your shipment with the Bill of Materials.
If there is a shortage or wrong material,
call Dealer Service immediately.

Safety is important!
Wear Safety Glasses and Work Gloves.
Follow all safety practices while assembling
and installing this product.

Dura-Bilt Products, Inc. P.O. Box 188 Wellsburg, N.Y. 14894

Dealer Service 570-596-2000 E-Mail info@durabilt.com

DURA-BILT RESERVES THE RIGHT TO CHANGE DESIGN AND/OR SPECIFICATIONS WITHOUT NOTICE.

Door Closer Components and Instructions

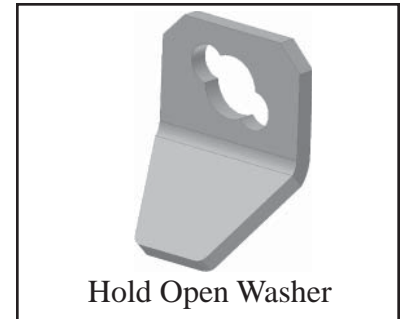
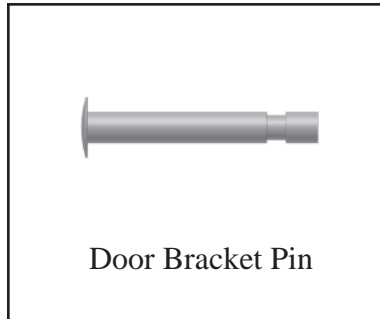
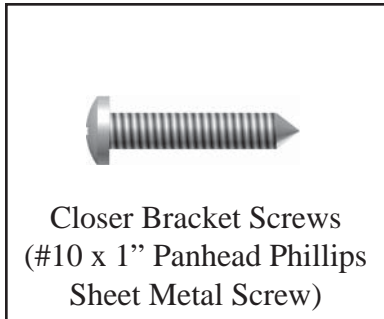
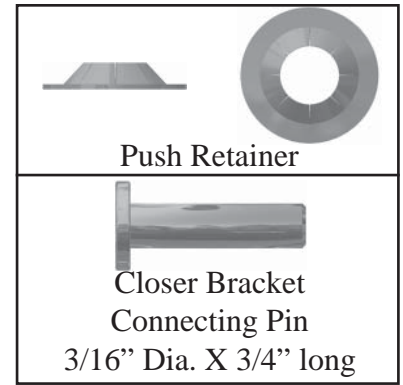
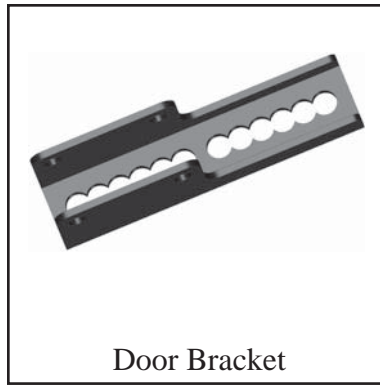
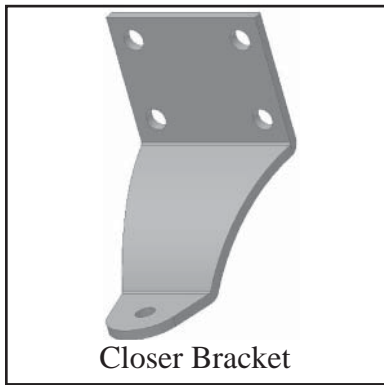

Instructions

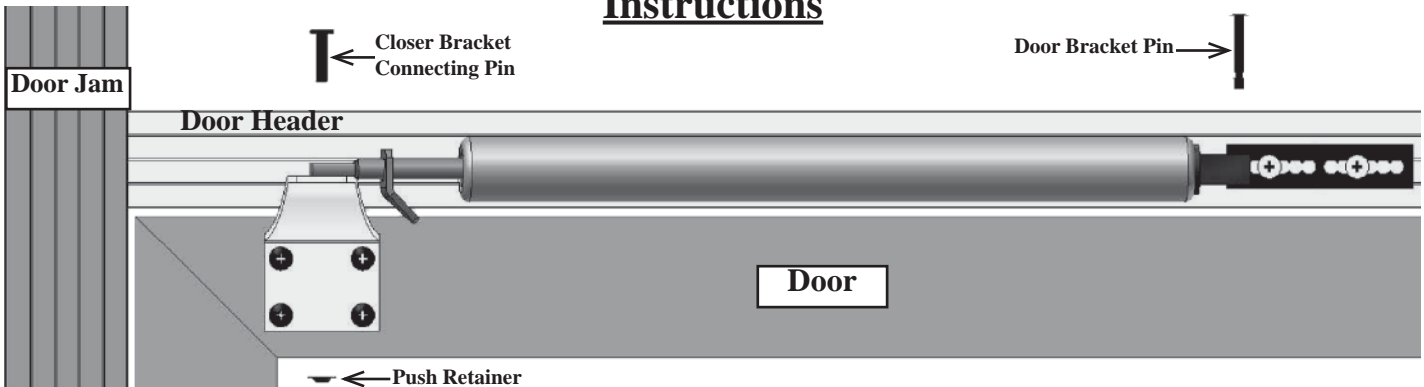

1. Locate and pre-drill the four (4) factory marked Positions with a 9/64" drill. Attach the Closer Bracket to the Door oriented as shown with four (4) Closer Bracket Screws.
2. Slide the Hold Open Washer on to the Shaft of the Door Closer as shown.
3. With the Hold Open Washer on the Shaft slide the Closer Bracket Connecting Pin through the Closer Bracket and through the shaft of the Door Closer, then using a pair of pliers squeeze the Push Retainer on to the Pin.
4. With the Door Closer attached to the Closer Bracket, insert the Door Closer into the Door Bracket and attach it with the Door Bracket Pin.

NOTE: The Closer is in **Maximum** latching power position with (pin in Hole 1). If less power is required, hold door open with Hold Open Washer, pull Door Connecting pin and relocate in Hole 2.

Door Handle Components and Instructions

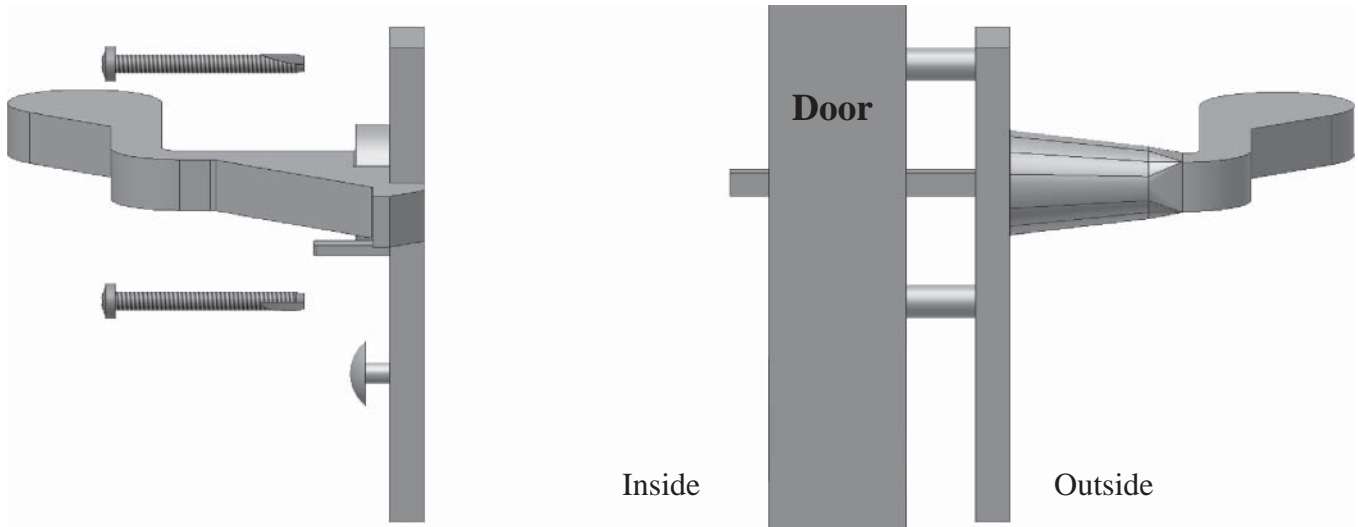
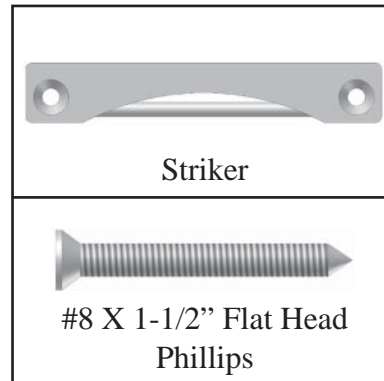
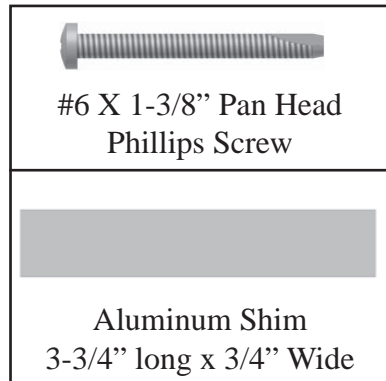
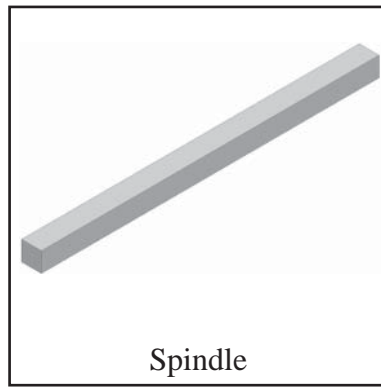

1. Insert the Spindle into the Outside Handle and line up holes, then push the Outside Handle on to the door.
2. Line up the Inside Handle with the Outside Handle use two (2) #6-32 x 1-3/8" pan head self tapping screws to join the whole assembly.
3. Center the Aluminum Shim under the Striker and line up with the Inside Handle Latch, then drill two (2) 1/8" holes through the Shim and Door Jam and install two (2) #8 x 1-1/2" flat head phillips screws.

Deadbolt Components and Instructions

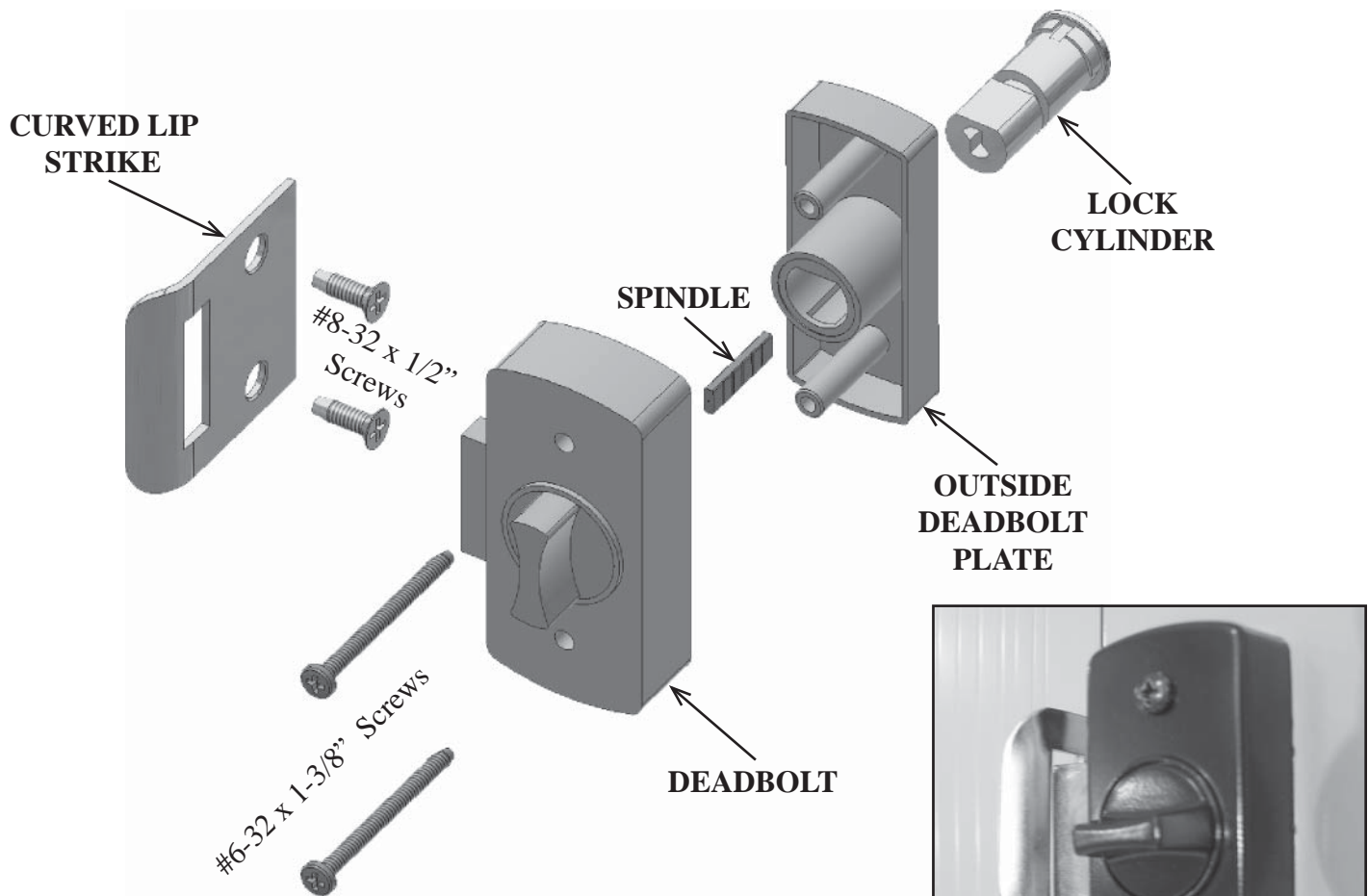

Step 1

Assemble key and cylinder to outside deadbolt plate by inserting the key and cylinder into the outside deadbolt plate and turning the key one half turn. Remove key from cylinder prior to further installation.

Step 2

Cut spindle to 3/4" long and assemble spindle to outside deadbolt assembly.

Step 3

Insert outside deadbolt assembly (with spindle) from outside of door.

Step 4

Install dead bolt on inside of door with bolt facing jamb; install two (2) #6-32 x 1-3/8" pan head self tapping screws.

Step 5

Extend bolt and mark the location of the curved lip strike on the jamb.

Step 6

Mark and pre-drill two holes using a 1/8" drill and install the curved lip strike with two #8-32 x 1/2" long flat head Phillips thread cutting screws.